

# **STRATIFIED**

## **Aux Fuel System**

### **EcoBoost 2.0/2.3**

**Additional Fuel Injection System**

# **Installation and User Guide**





**Thank you and congratulations on the purchase of your new Stratified 4-Port Auxiliary Fuel System. Follow this document to ensure safe and proper installation and operation of your new device.**

### **WARNINGS AND WARRANTY – PLEASE READ CAREFULLY**

ALL parts are sold for OFF ROAD RACE-ONLY ground vehicle use only. Aftermarket systems interacting with engine function are not for use on pollution-controlled vehicles. Alteration of emission related components constitutes tampering under most local emission regulation guidelines and can lead to fines and penalties.

#### **Limited Warranty**

This Stratified product is warranted against defects in materials and workmanship for ninety (90) days from date of purchase. During the warranty period, Stratified will repair, or at its option replace at no charge, components that prove to be defective. The product must be returned, shipping prepaid, to a Stratified facility. This limited warranty does not apply if the product is damaged by accident or misuse. The foregoing warranty is in lieu of all other warranties expressed or implied including but not limited to any implied warranty of merchantability, fitness, or adequacy for any particular purpose or use. Stratified Automotive Controls Ltd. is not responsible for any fines, injuries, or damages incurred as a result of the installation or use or misuse of our products. It is the complete responsibility of the purchaser of such products to ensure that they are used in a legal, safe, and appropriate manner.

**DISCONNECT THE NEGATIVE BATTERY TERMINAL BEFORE PERFORMING ANY ELECTRICAL WORK ON YOUR VEHICLE. IF YOU DO NOT FEEL COMFORTABLE MAKING THESE MODIFICATIONS, HAVE THEM PERFORMED BY A PROFESSIONAL.**



---

## Table of Contents

---

1.	Features and Benefits .....	4
2.	Introduction and Precautions.....	5
3.	Parts Included .....	6
4.	Installation Diagram.....	7
5.	Installation Instructions .....	8
6.	Software Install & Tuning .....	23
7.	Trouble Shooting .....	31

## 1. Features and Benefits



### **Protects your Engine from Fuel Starvation:**

To make more power you need two main components. Air and Fuel. With more boost and bigger turbochargers or superchargers, your OEM direct injection components can't supply the fuel needed for safe high power operation. This auxiliary port injection system is a proven method for keeping your motor safely fueled under the most demanding conditions.



### **Provides The Fuel you Need for More Boost and Power:**

Direct injection cars use expensive and complex components. When upgrading your vehicle to produce more power than stock, more fuel is needed. Direct injection injectors and fuel pumps are often not upgradeable. This fuel system augments your fueling under high power levels with proven components allowing you to achieve your power goals.



### **Cleaner Valves, Efficient Motor:**

The direct injection (DI) system is very efficient and has cooling benefits. Keeping it in the car and working as intended is ideal. This is why a port injection system works so well. You keep the efficient DI fueling and augment it with port injection only under high power. This also has the benefit of keeping your intake valves cleaner.



### **Easy Installation:**

We have worked very hard to make our systems as plug and play as possible. The kit you purchased is built and tested for your vehicle. This means everything fits right and works as it should from the get-go making it a painless and effective installation process.



### **Tested, Proven, Safe Solution:**

We don't build and sell anything that we don't thoroughly test. The fuel system is a proven, safe solution for increasing fueling on your vehicle and we stand behind its performance, capabilities, and reliability.



### **E85 Safe, Simple Adjustments:**

All kit components are E85 safe. The controller that calculates the fuel delivery as well as all components are purpose built and safe. We make adjusting the fueling as simple as possible to make sure you get to your results quickly whether we tune the system or someone else does.



### **Split Port Directional Injection with Angled Port Matching:**

Features injectors oriented towards the cylinder head that spray with a split stream pattern to ensure even fuel distribution to each intake valve. The ports on the spacer are also matched to the angle at the mating surface between the intake manifold and cylinder head to ensure that the transition of airflow towards the engine remains smooth.

---

## 2. Introduction and Precautions

---

***IMPORTANT: When installing and working with the Auxiliary Fuel System you are working with flammable fluids. Take all safety precautions necessary during installation and operation of the fuel kit to prevent any fires or injuries. This means ensuring you are installing the system in a well-ventilated area away from any spark or flame source. After the installation and periodically thereafter check that the system continues to be leak free.***

The Aux Fuel System Electronic Controller should be mounted within the vehicle's engine bay, but it is **NOT water proof**. The controller should not be mounted directly on the engine. Do not spray or pressure wash the controller with water or any other liquids. Mount the controller in an area that is not in contact with the engine - preferably close to other vehicle electronics such as the fuse box.

The direct injection (DI) system in your vehicle is designed to supply enough fuel to run the OEM vehicle with OEM components. Most manufacturers build some headroom into their fueling systems but at some point, your quest for power requires more fuel. On a direct injected car this means that you need to upgrade at least the fuel injectors or high pressure fuel pump or often both. These upgrades are expensive and often not available.

The Stratified 4-Port Auxiliary Fuel System is designed to work in conjunction with your DI fuel system and offer additional fuel when needed under high boost or high power demands. This means that your car remains efficient and driveable while having the fueling capacity to reach higher power goals.

### 3. Parts Included

Verify that all these components are included with your fuel system kit:

<b>Item</b>	<b>Specifics</b>
1x – X <sup>4</sup> tra Fuel Kit Assembly	<ul style="list-style-type: none"> <li>• 1x – Intake Spacer</li> <li>• 1x – (-8 AN) ORB Plug</li> <li>• 1x – Fuel Rail</li> <li>• 4x – Fuel Injector</li> <li>• 2x – Rail Mounting Screws</li> <li>• 4x – Intake Manifold Gasket</li> <li>• 1x – M8 x 55 Spacer Bolt / Washer</li> <li>• 2x – M6 Screws, Nuts and Washers</li> <li>• 4x – M5 Screws</li> <li>• 2x – Engine Cover Spacers</li> </ul>
1x – Fuel Line Tap	N/A
1x – Fuel Line (2ft.) w/ Fittings	<ul style="list-style-type: none"> <li>• 1x – (-8 AN) 90 Deg. Fitting</li> <li>• 1x – (-6 AN) 90 Deg. Fitting</li> </ul>
Fuel System Controller Box	<ul style="list-style-type: none"> <li>• 1x – 4-Port Controller w/ Strat Sticker</li> <li>• 1x – Add-a-fuse</li> <li>• 1x – 5A Fuse</li> <li>• 1x – Ring Terminal for Ground</li> <li>• 4x – Injector Connectors</li> <li>• 1x – Cam Sensor Connector</li> <li>• 1x – Map Sensor Connector</li> <li>• 1x – Stratified Harness Assembly</li> </ul>
Hardware Bag	<ul style="list-style-type: none"> <li>• 10x – Zip Ties – Small</li> <li>• 3x – Zip Ties – Large</li> <li>• 2x – 3M Dual Lock Strips</li> </ul>
1x – Fuel Disconnect Set	N/A

## 4. Installation Diagram

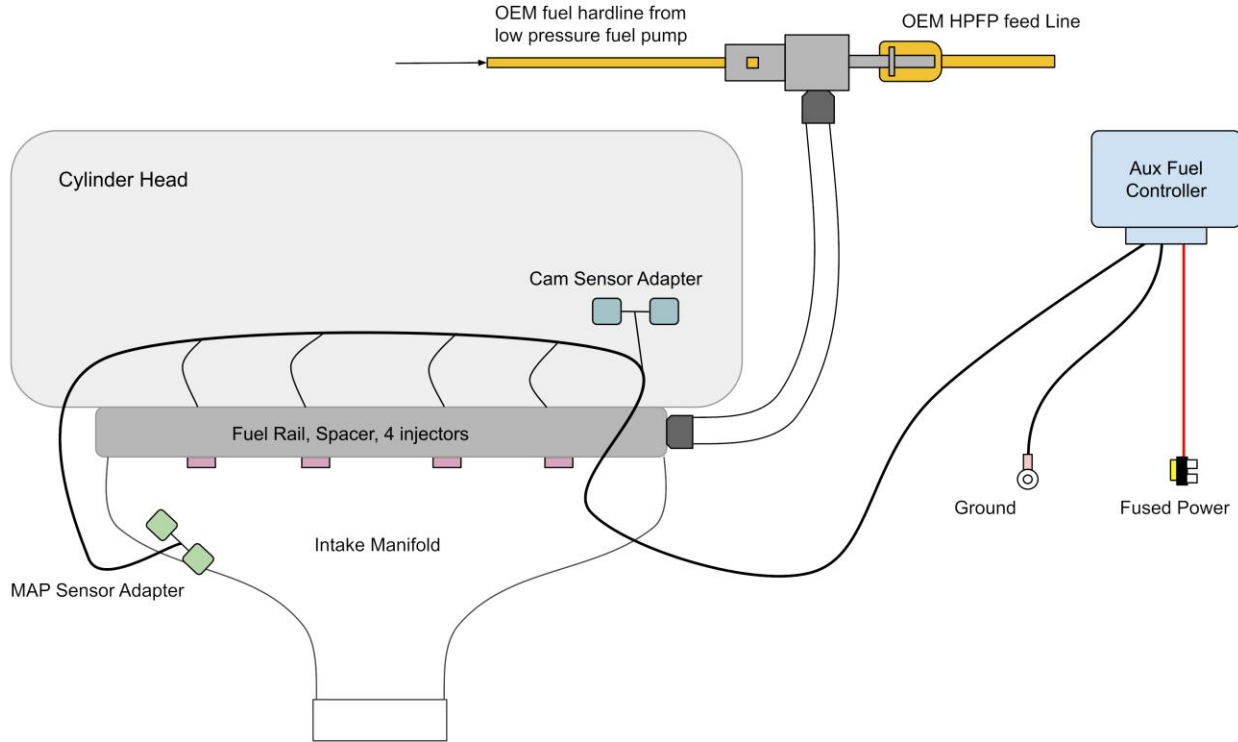



---

## 5. Installation Instructions

---

**IMPORTANT: When installing and working with the Auxiliary Fuel System you are working with flammable fluids. Take all safety precautions necessary during installation and operation of the fuel kit to prevent any fires or injuries. This means ensuring you are installing the system in a well-ventilated area away from any spark or flame source. After the installation and periodically thereafter check that the system continues to be leak free.**

 **WARNING:** Before working on or disconnecting any of the fuel tubes or fuel system components, relieve the fuel system pressure to prevent accidental spraying of fuel. Fuel in the fuel system remains under high pressure, even when the engine is not running. Failure to follow this instruction may result in serious personal injury.

 **WARNING:** Do not smoke, carry lighted tobacco or have an open flame of any type when working on or near any fuel-related component. Highly flammable mixtures are always present and may be ignited. Failure to follow these instructions may result in serious personal injury.

 **WARNING:** Clean all fuel residue from the engine compartment. If not removed, fuel residue may ignite when the engine is returned to operation. Failure to follow this instruction may result in serious personal injury.

 **WARNING:** Do not carry personal electronic devices such as cell phones, pagers or audio equipment of any type when working on or near any fuel-related component. Highly flammable mixtures are always present and may be ignited. Failure to follow these instructions may result in serious personal injury.

 **WARNING:** Always disconnect the battery ground cable at the battery when working on an evaporative emission (EVAP) system or fuel-related component. Highly flammable mixtures are always present and may be ignited. Failure to follow these instructions may result in serious personal injury.

 **WARNING:** When handling fuel, always observe fuel handling precautions and be prepared in the event of fuel spillage. Spilled fuel may be ignited by hot vehicle components or other ignition sources. Failure to follow these instructions may result in serious personal injury.

 **WARNING:** Avoid contact with fuel during a visual inspection for fuel leaks with the engine running. Do not work on the fuel system until the pressure has been released and the engine has cooled. Fuel in the high-pressure fuel system is hot and under very high pressure. High-pressure fuel may cause cuts and contact with hot fuel may cause burns. Failure to follow these instructions may result in serious personal injury

1. First to relieve the fuel pressure in the OEM fuel system. This is done by pulling use F56 from the body control fuse module which is in the passenger footwell underneath the glove box. Remove the panel insulator from below.

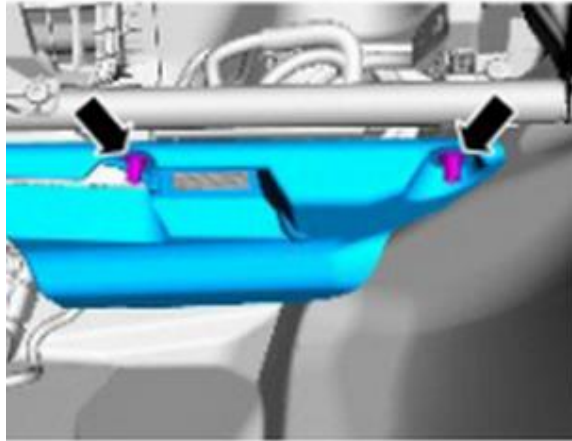

2. Remove Fuse F56 from the body control module.



3. Now start the car and wait for the engine to stall. Once it has stalled, crank for another 20 seconds to ensure fuel pressure is relieved.
4. Turn the key to the OFF position and keep the fuse out of the panel until the fuel kit installation is complete. This might trigger some engine codes. Clear these after the installation.
5. **Remove the negative battery cable.**

- The intake spacer, rail and injectors should be installed next. The easiest way to install them is by removing the intake manifold from the vehicle and performing the installation on a bench. This also gives you the opportunity to inspect your intake valves. They will look cleaner after you run the aux fuel system!
- Jack up the front of the vehicle and secure it. Remove the underbody panels

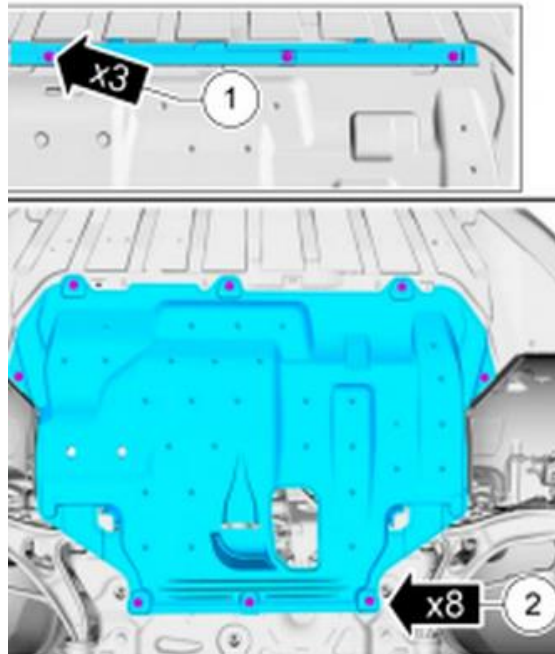

- Disconnect your charge piping from the throttle body and push it down slightly.

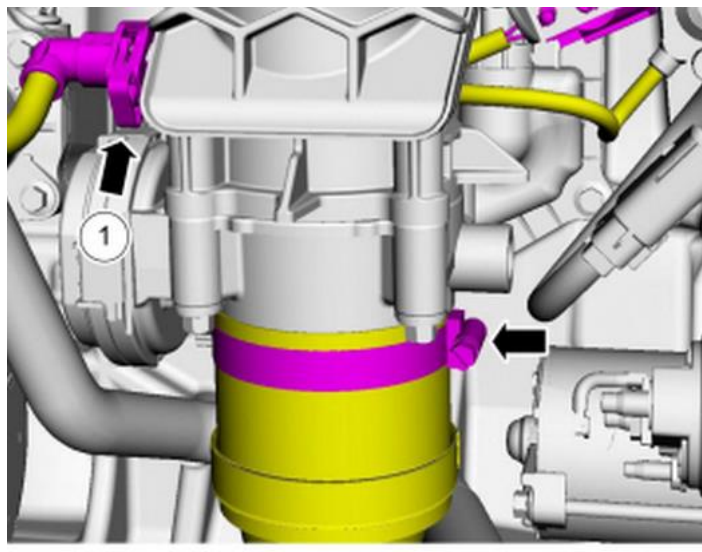

9. Disconnect the vacuum and electrical connections from the manifold and throttle body as shown below:

**NOTE:** The sound symposer may not fit with the fuel kit on the Focus ST. If you haven't already done so, remove the symposer and block it off with a plate.

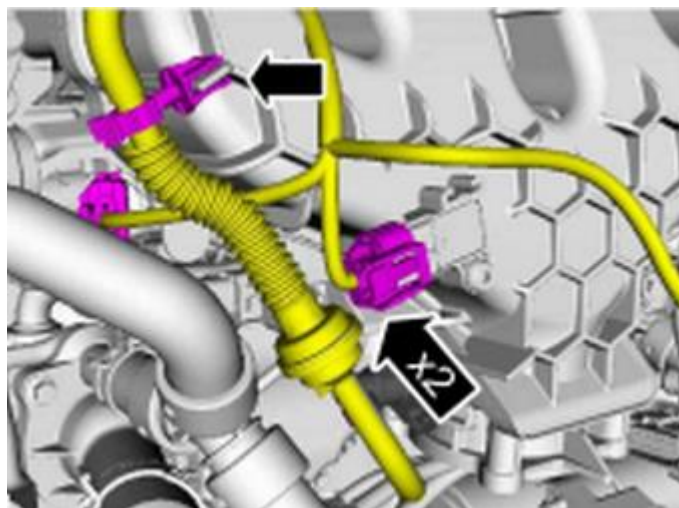
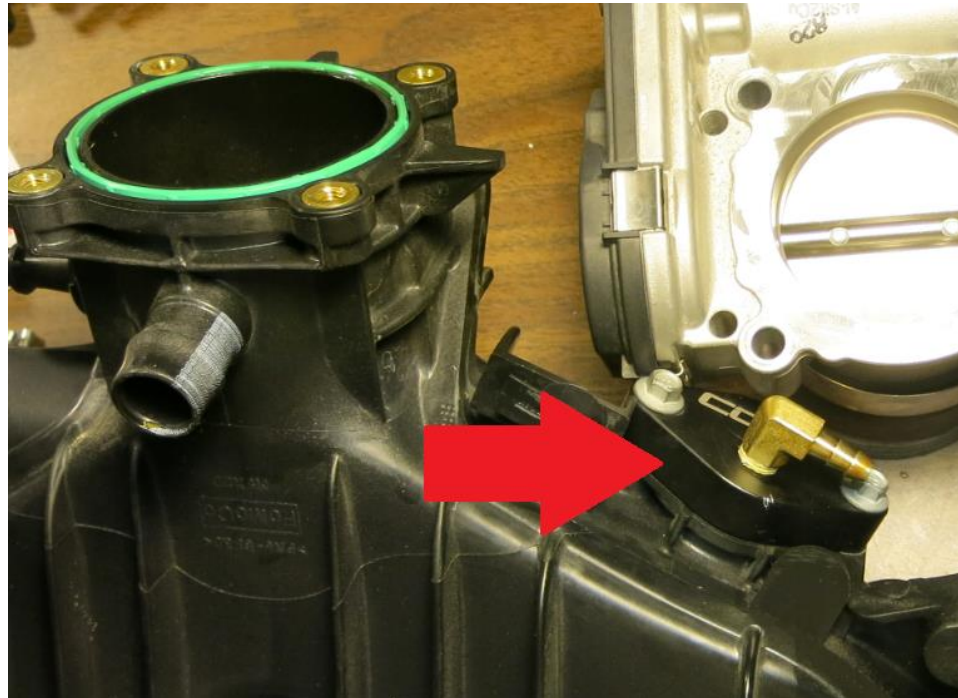

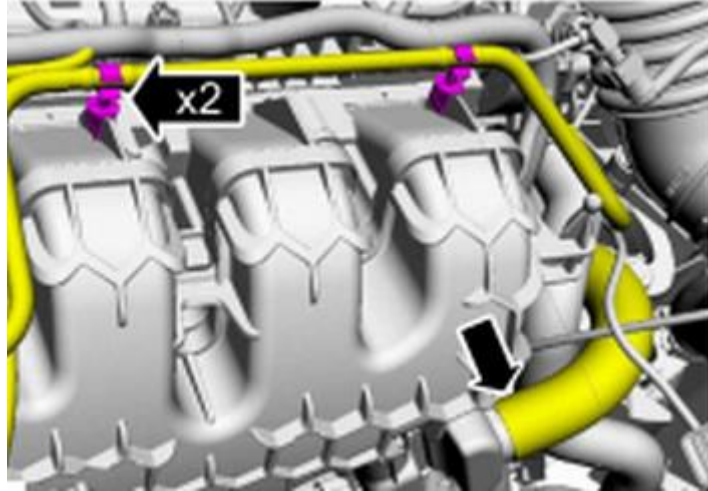

**NOTE:** The throttle body electrical connector can be a little tricky to disconnect. It might be useful to loosen the intake manifold to give yourself more clearance.

**NOTE:** Be careful with the quick connect vacuum hoses and lines. The clips can be fragile if not handled carefully.

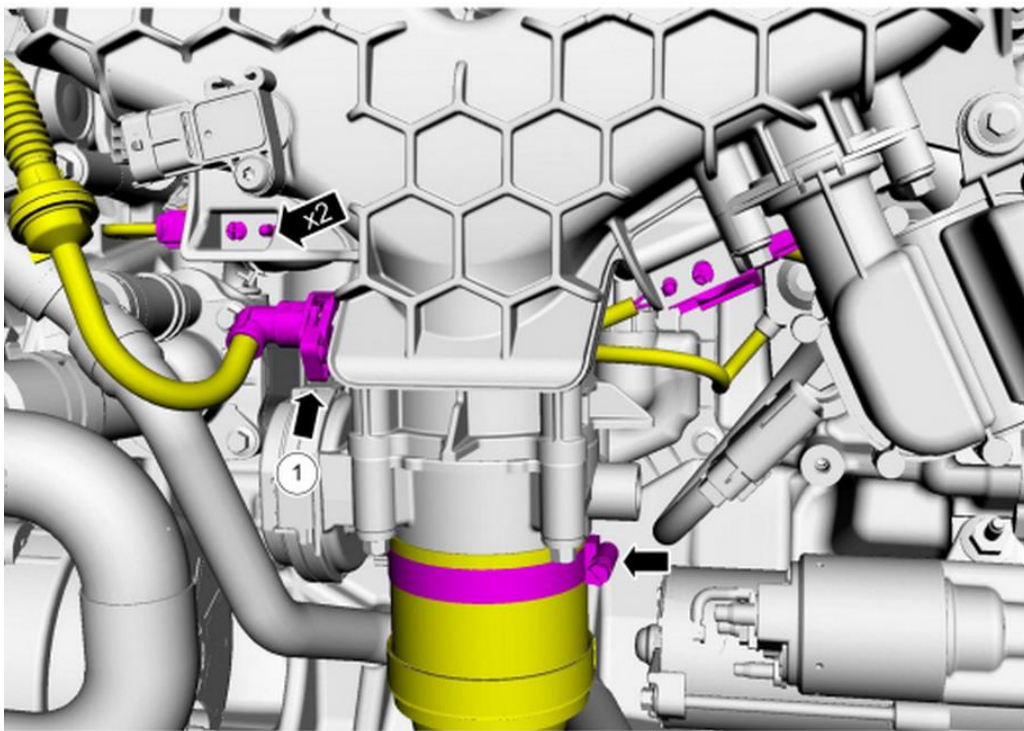

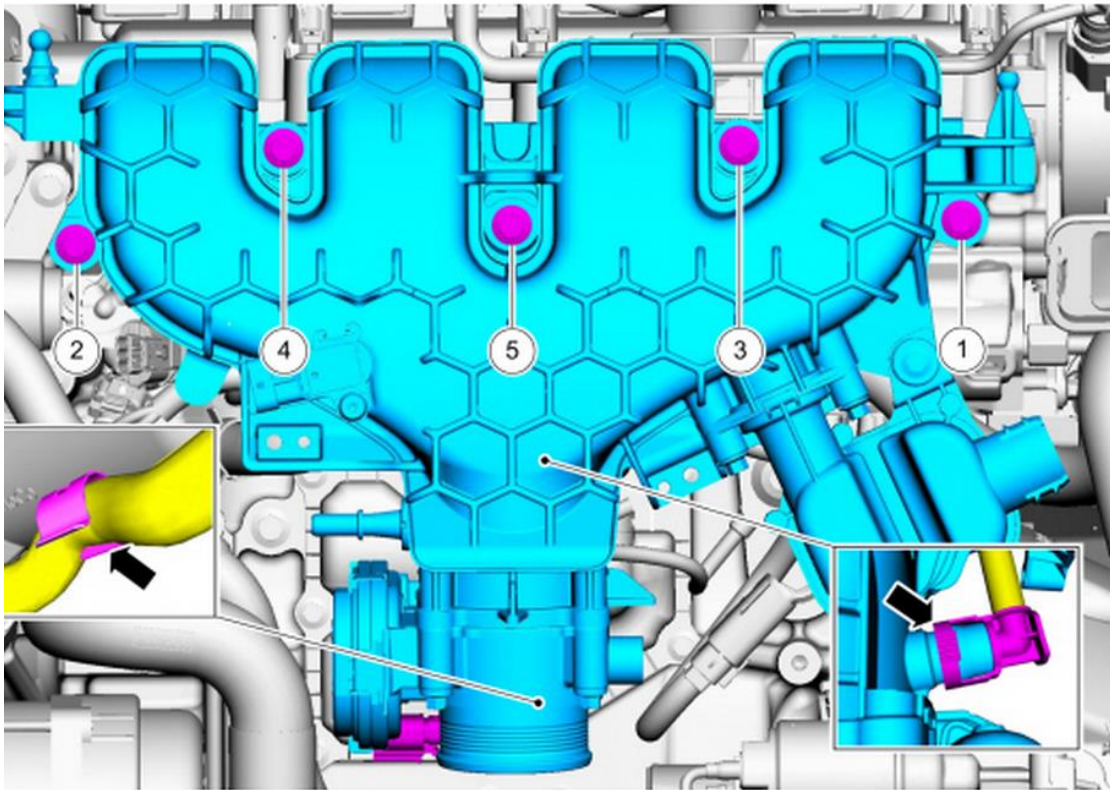

10. Inspect the manifold-to-head insulating gaskets, make sure they stay in place during the re-install.

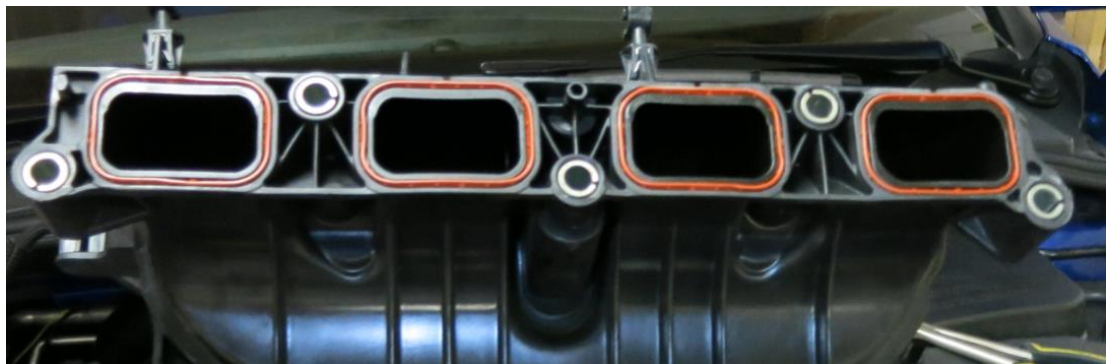

11. The kit comes with injector pre-installed with the radium fuel rail and spacer kit, follow the steps from link below to modify the stock intake manifold to allow fitment.

<https://data.radiumauto.com/PublicDocs/19-0155B.PDF>

12. Make sure the intake gasket sits correctly into the grooves of the spacer before the install.



13. Mount the plate to the head using the M8 Washers and M8x40mm bolts provided. (Step 10 from radium instructions)



14. The installation of the intake spacer will offset the throttle body upwards and towards the front of the car. Massaging the couplers on the cold pipe will allow fitment.
15. You may need to slightly move the AC line towards the front of the car. Do this using your hand, it needs the slightest amount of bending to clear the manifold.
16. Install the manifold assembly back onto the engine and connect all hoses and electrical connections.
17. Install the Stratified Aux Fuel Flexible line -8AN male fitting onto the fuel rail. This connection does not need any sealants or tape.



18. Run the fuel line underneath the air intake tube and towards the rear of the motor watching that it does not come into contact with any abrasive surfaces.
19. Thread the Stratified Aux Fuel Flexible line -6AN male fitting into the provided fuel line tap. There is Teflon tape on the fitting, more or less may be needed if the line does not seal due to the nature of the tap.



20. Disconnect the high pressure fuel pump (HPFP) feed line from behind the HPFP. It is marked by a red arrow below. This rubber flexible feed line connects to a supply hard line coming from the tank. The line is 5/16" and the best tool to use for disconnecting it is the one supplied in the kit. Select the 5/16" collar from the kit.

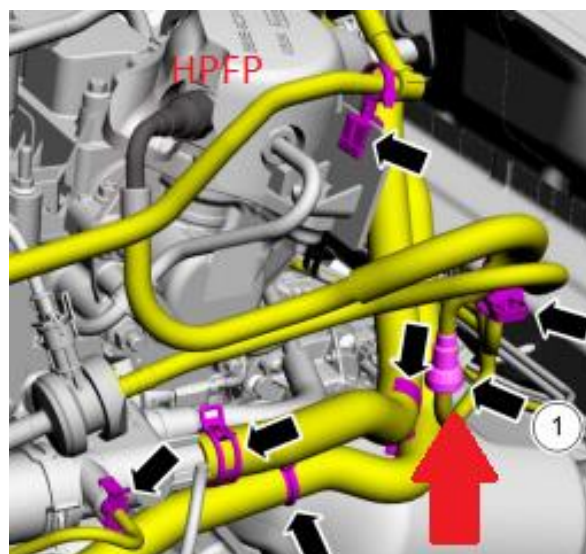

21. Place the 5/16" collar on the hard line where the arrow is pointing with the flat section away from the fuel line connector and push it between the connector and hard line. The connector should pop off without much force.

**WARNING: Watch for fuel spray and leaking when disconnecting the fuel line.**

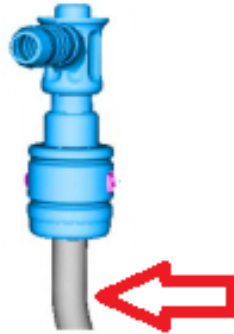

22. Place the fuel line tap on the 5/16" hard fuel supply line and re-attach the HPFP feed line to the top of the tap. Make sure all fuel connections click into place.

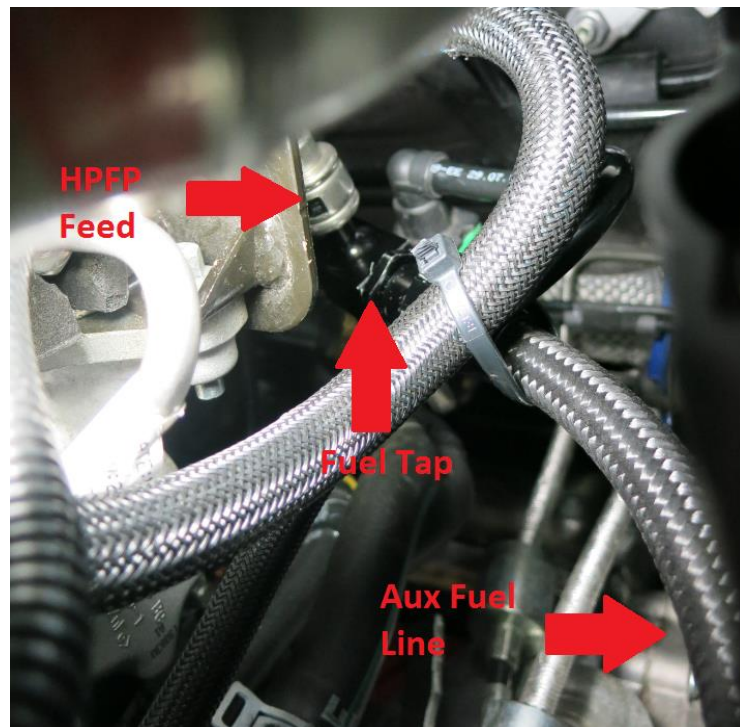

23. Secure the fuel line using the large Zip ties.
24. Now it is time to install the controller. Below is the controller and the wiring connections.

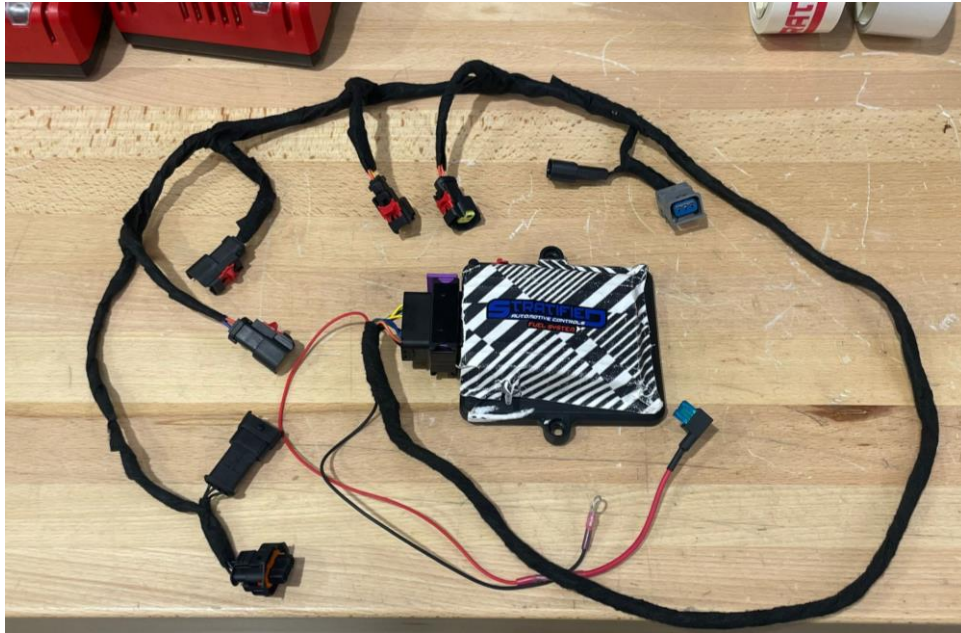

25. Start by removing the air filter box assembly from the engine bay.
26. Secure the Stratified Aux Fuel Controller to the top of the fuse box using the 3M dual lock provided.

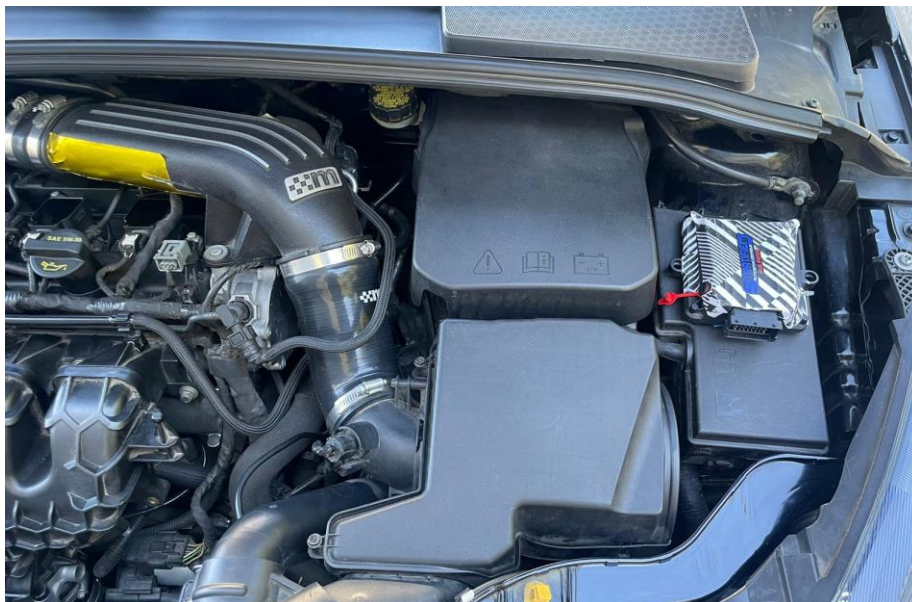

27. Open the fuse box and install the Add-A-Fuse supplied to one of the switched fuse locations in the fuse box by the battery. We tested the location shown below. It **did not** have an existing fuse. If the location you use has an existing fuse, make sure that fuse is rated for at least **10A and is switched with ignition**. Place the removed fuse in the second position of the Add-A-Fuse holder or that circuit will no longer work.

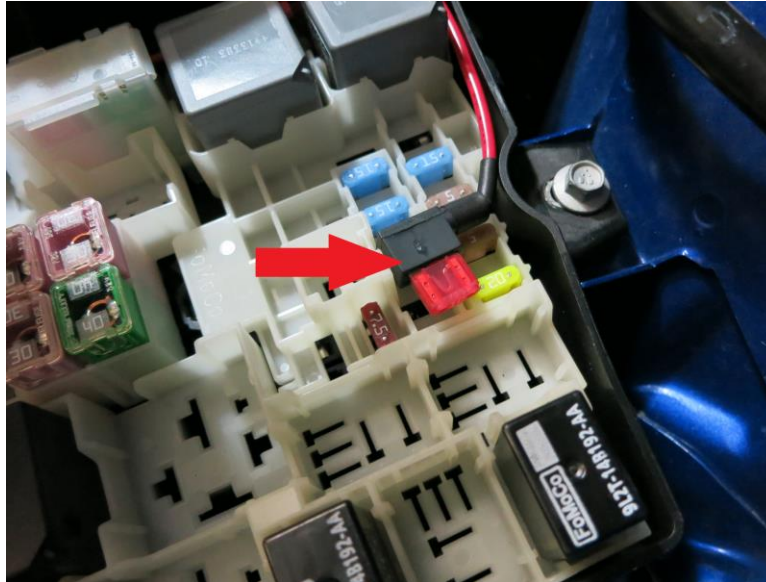

28. Locate the ground wire underneath the air filter box held by a 10mm bolt and bolt down the ring terminal from the Stratified Aux Fuel Controller harness.

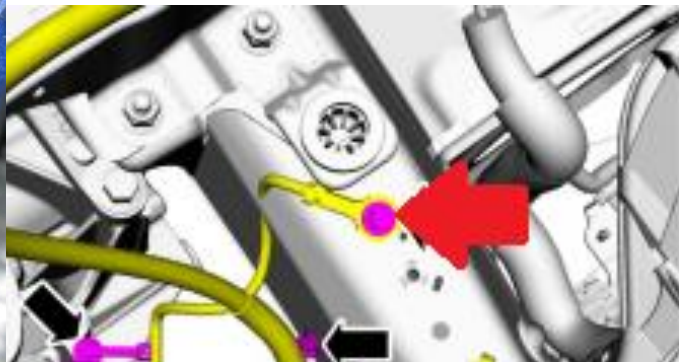

29. Leave the controller connector at top of the fuse box, run the wiring loom below the intake then to the top of engine on the right side.



30. Now it is time to get your RPM signal connected. The wiring loom uses an adapter harness to read the RPM signal directly from the cam sensor. Remove the OEM cam sensor connector, attach OEM connector to the adapter harness and connect the new grey connector to the OEM cam sensor. Use a zip tie to secure the connector to the wiring loom.

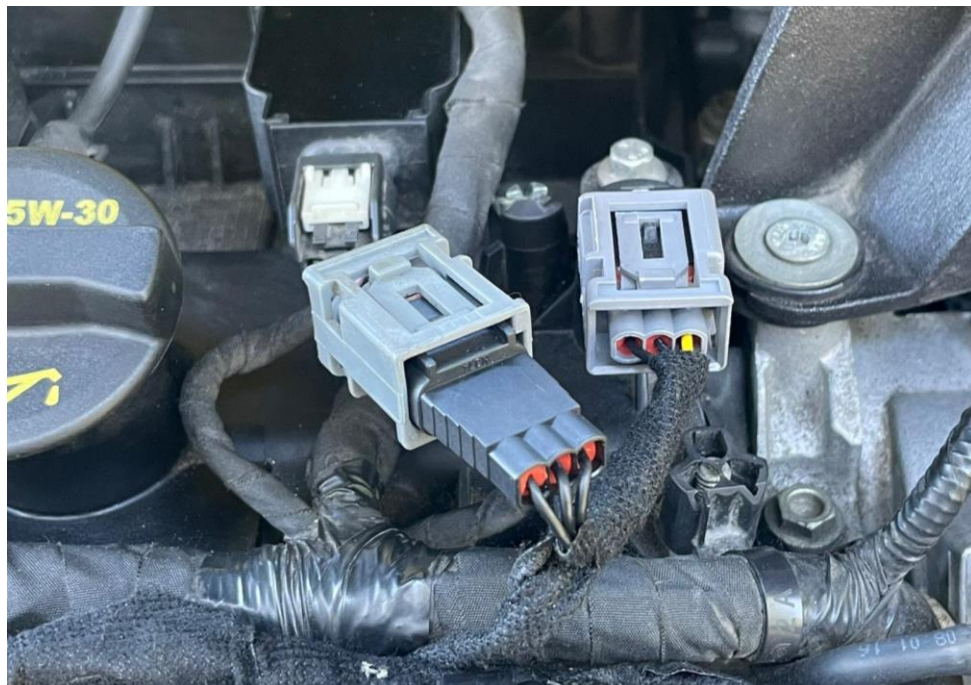

31. Run the four injector connectors and wires behind the fuel rail and connect them to the four auxiliary injectors on top of the spacer.
32. Now it's time to connect to the MAP sensor wire. The OEM MAP sensor is located on front of the intake manifold. Remove the OEM connector and connect the adapter harness. Use a zip tie to secure the adapter harness to the wiring loom.

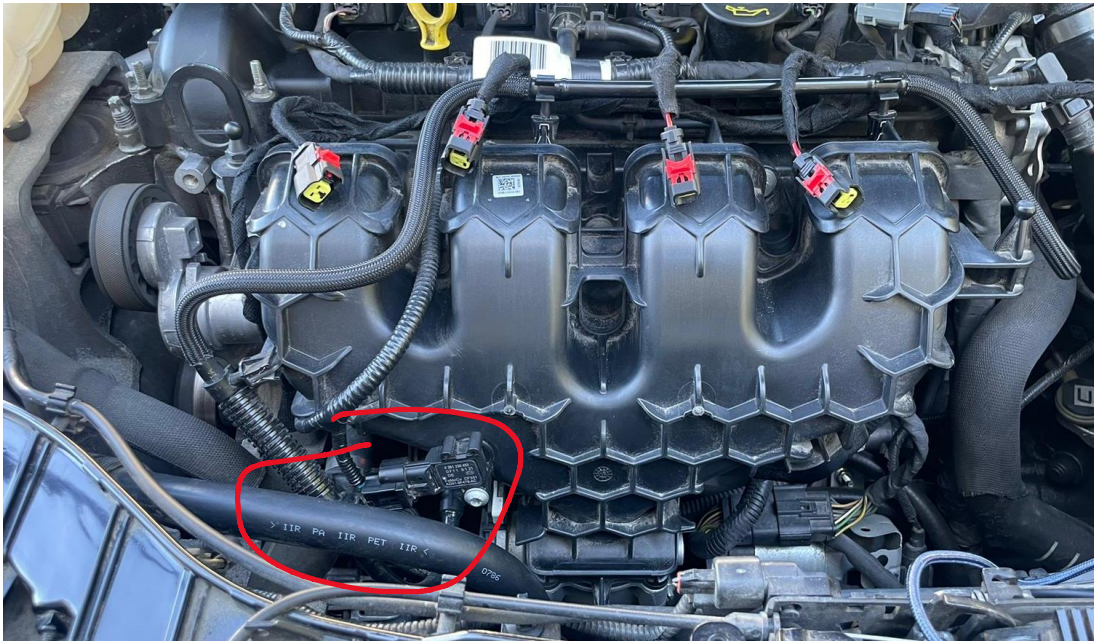

33. Bundle the wiring behind the rail and strap it down. Using the small zip ties, bundle and secure the wiring loom so that it is not going to rub or become damaged over time.



34. Now that everything is in place, reinstall the air filter box and check all your electrical, vacuum, and fuel connections.
35. Replace fuel pump fuse F56 in the passenger footwell body control module.
36. Reconnect the battery.
37. Turn the key to the ON position to prime the fuel system but do not start the car. Go to the engine bay and ensure there are no fuel leaks of any kind.

---

## 6. Software Install & Tuning

---

Your Aux Fuel Controller comes preloaded with a base map file. The following instructions are for when you want to confirm it's working correctly or upload a new tune file to the controller.

1. Get your tuning laptop ready with supplied USB-C cable. Any USB-C cable that supports data transfer will work.
2. Remove the USB cable dust cover and connect the controller to your laptop computer.



3. The controller is programmed using TunerStudio Software (use the Windows version, you can download the software bundle from our website).
4. From the downloaded package, locate and extract the .ini file called [Stratified\_aux\_firmware.ini]. You will use this file to setup the TunerStudio Project for the Stratified Aux Controller.

5. After you install the TunerStudio Software, you will need to create a new project to connect to the Stratified Aux Controller. Open the TunerStudio software, select [**Create New Project**]. It will create the project under \Documents\TunerStudioProjects\ProjectName\.
6. Under Firmware section, check the box before [Other / Browse], then locate the downloaded [**Stratified\_aux\_firmware.ini**] file.

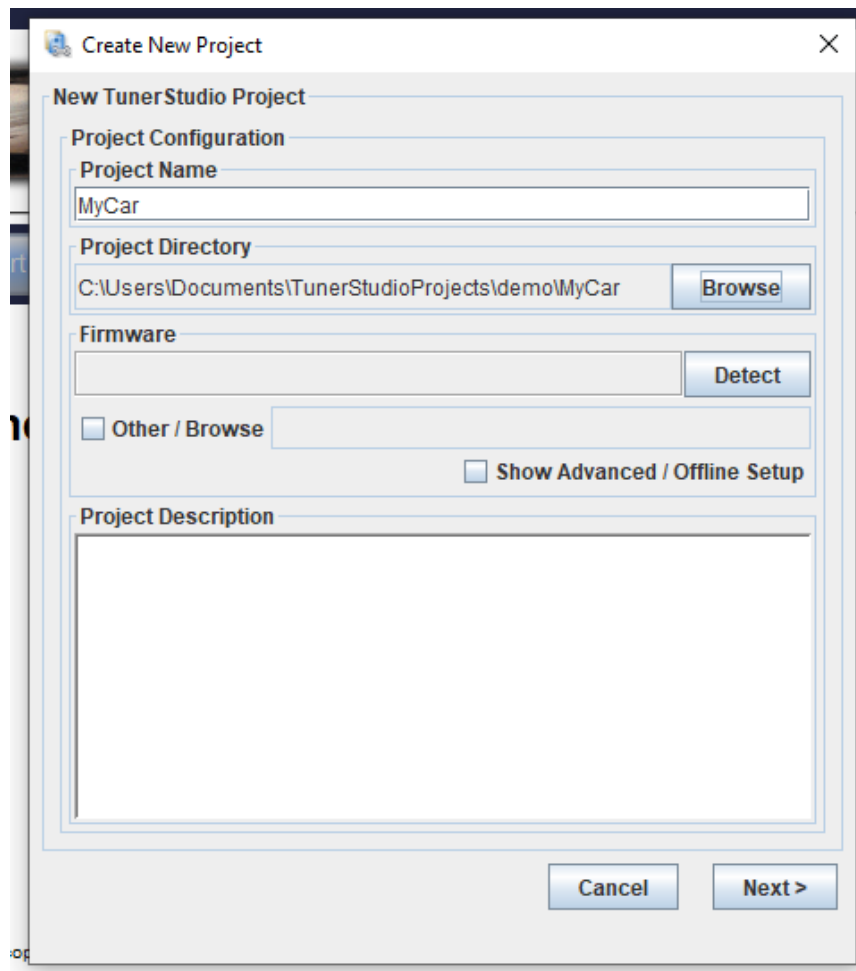

7. Next we need to find out which port was used by the controller to connect to the computer. To do this, power the controller by turn on the ignition on, engine off. Connect the USB-C to the computer, search and open the [**Device Manager**] under the windows taskbar.

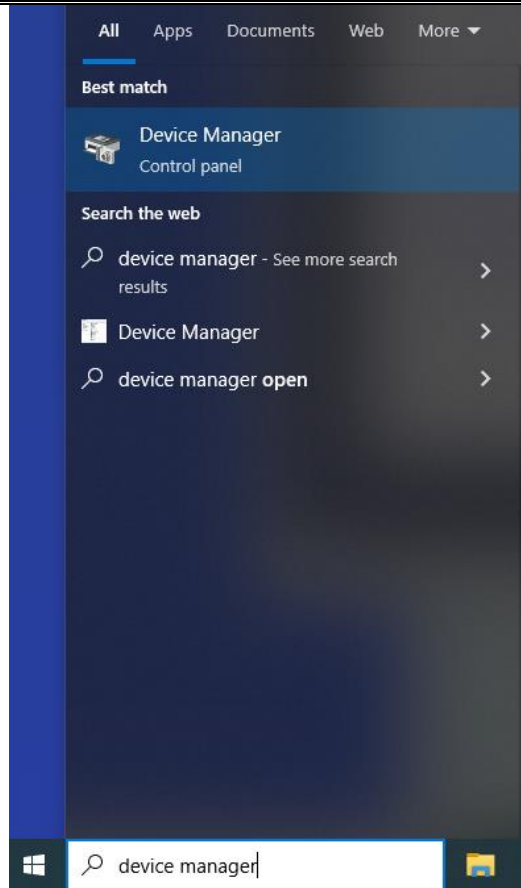

8. The controller should show as [USB Serial Device (COM#)] or [USB to UART Bridge] under the Ports (COM & LPT) section. If you are unsure which port it is, you can unplug and replug in the controller and you will see it pop up. Remember that COM number then go to **Step 11**.

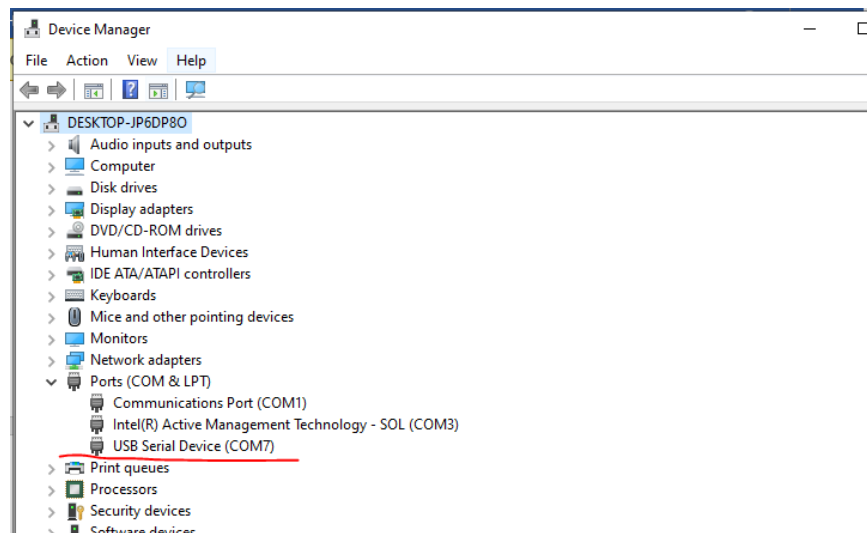

9. If there's no new COM port added when plugging in the controller, you will need to install a driver. To do this, go down the list in the device manager, under the **[Universal Serial Bus devices/controllers]**.

Once again plug in the USB-C to find the connected controller. It is usually named **[BLACK\_F407VE CDC in FS Mode]**.

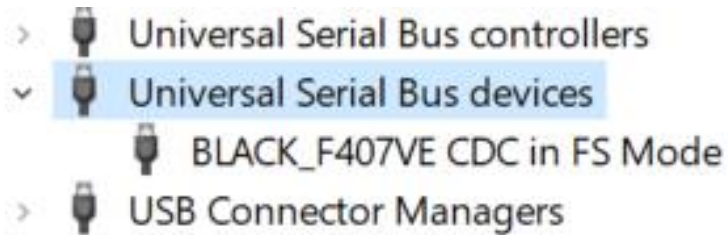

10. Right click on it, select **[Update Drivers] > [Browse my computer for drivers] > [Let me pick from a list of available drivers on my computer] > YOU MUST Choose [USB Serial Device] then [Next] to confirm.**

Once the driver is installed go back to Ports (COM & LPT) section, find the updated COM port that is now used.

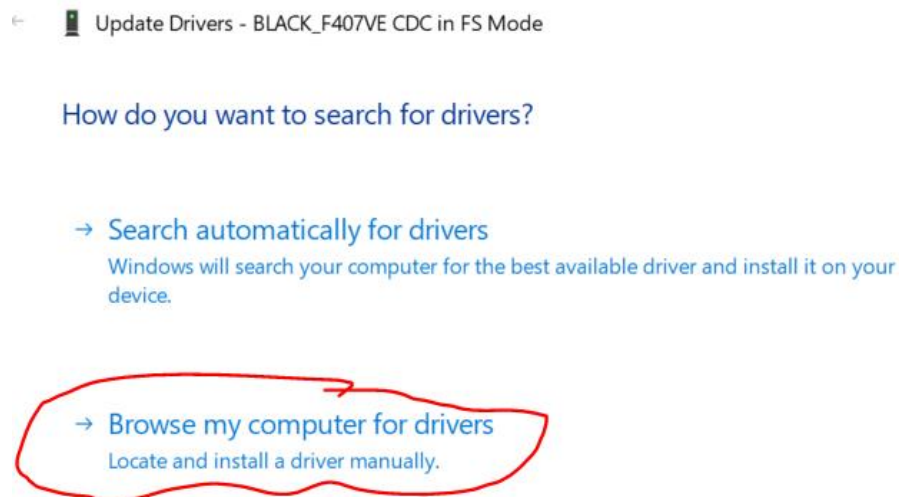

Show compatible hardware



11. Go back to TunerStudio software, select the Com Port # you remembered from previous step. Make sure Baud Rate is set to 115200, make sure the Bluetooth Port is **unchecked**, and click [Test Port]. Once it shows **Successful!!!**, select [Next >], click [Finish].

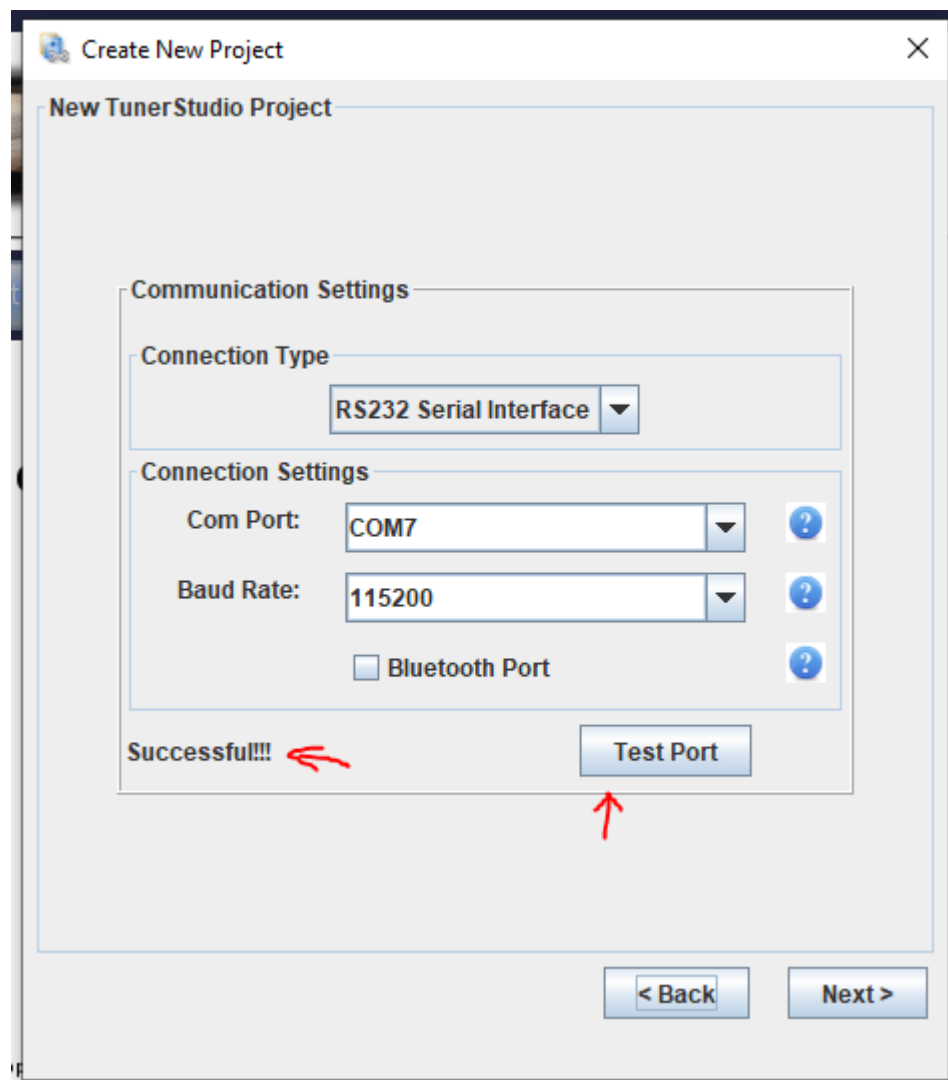

12. The controller comes with the tune pre-installed, before driving the car you must check the operation of the controller.
13. The Aux controller takes the MAP sensor voltage and reads it as a TPS signal. In the TunerStudio software, you will see your MAP readings as a TPS value from 0-100%. On a stock 3 bar MAP sensor, 25% TPS reading refers to approximately 1 bar absolute pressure which is atmospheric pressure at sea level.
14. To confirm the controller is in working condition, the TPS gauge should stay at around 25% when ignition on, engine off.
15. Start the engine and let it idle. Make sure the Engine Speed gauge reading on the dash is matching the actual engine RPM in the TunerStudio software. The TPS gauge will drop when letting off the throttle or idling due to vacuum in the manifold.

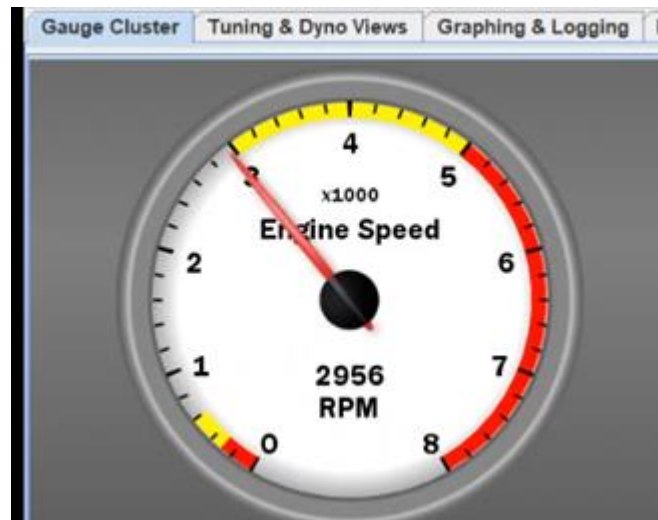

16. The fuel map is found under Tuning > VE tables. Only adjust this if you are instructed by your tuner or you are tuning the car yourself and have the knowledge to do so.

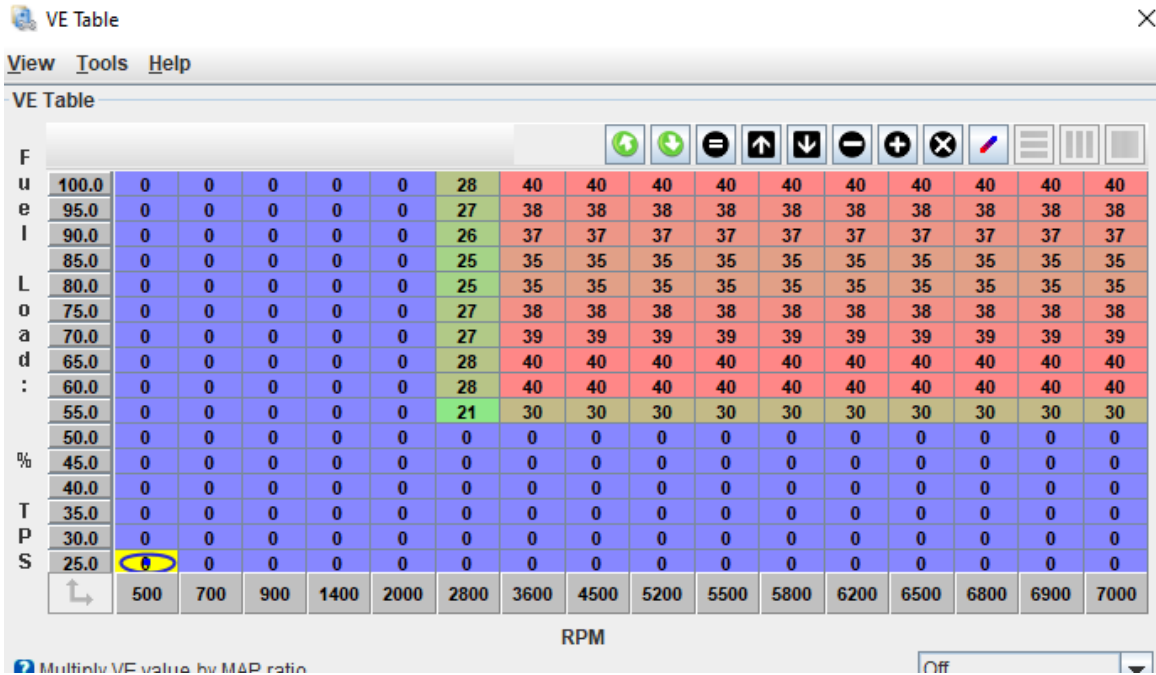

17. The final test is to determine if the aux injector is adding fuel.

Warm up the car and slowly enter boost. Once the car reaches higher boost levels the injector will open and start adding fuel. You can see this in the Pulse Width and Duty Cycle gauges which will move above 0.

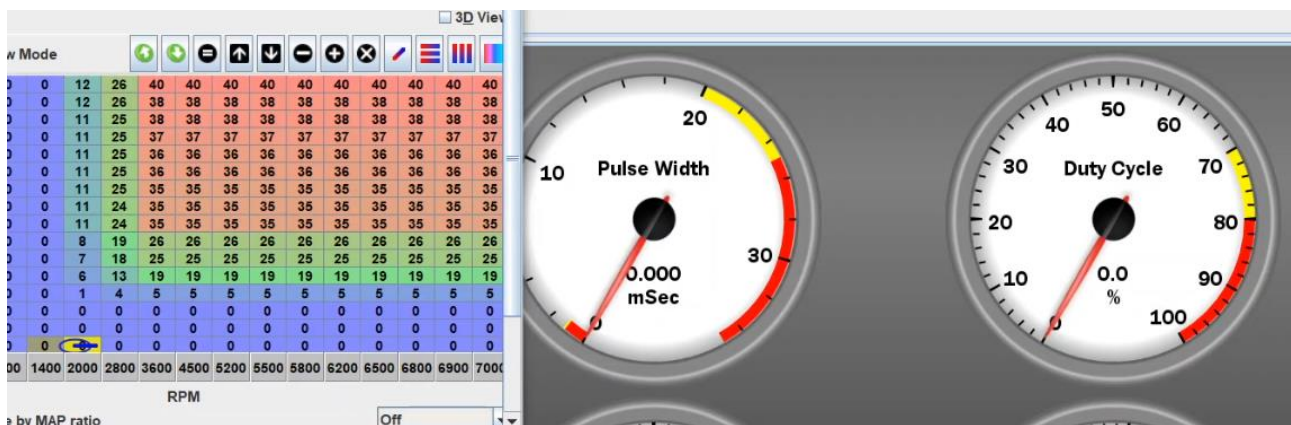

18. Congratulations, your aux fuel system is now setup. Time to tune it and enjoy the added fueling and performance!

## Flashing a New Tune on the Stratified Aux Fuel Controller

1. To flash a new file to the controller, connect the controller to the software, open the project you already created and make sure the controller is online.
2. Then select [File] > [Load Tune (.msq)], then select the new .msq tune file.
3. Confirm to burn then power cycle the key. Make sure the controller is actually power cycled. Some fuses in the engine bay may not power down when you cycle the power. If that is the case you can cycle the power on the controller by unplugging the it from the harness and plugging it back in.

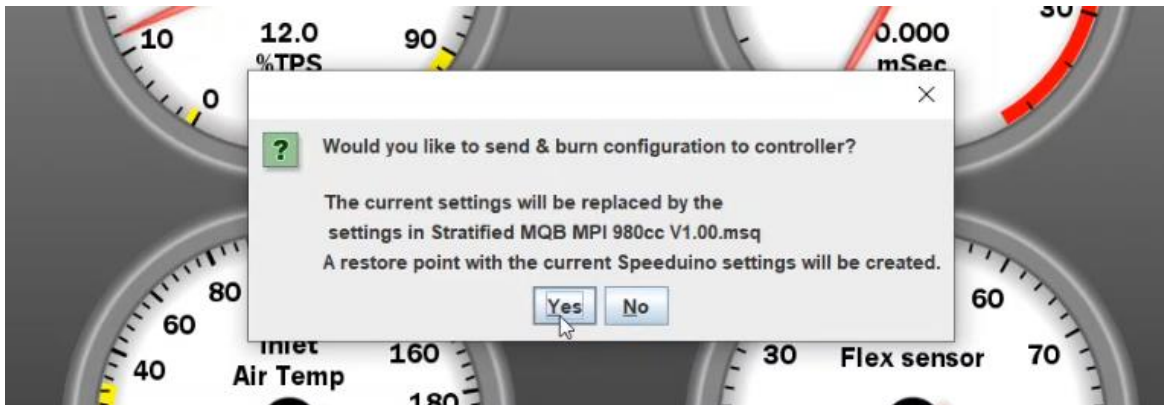

## 7. Trouble Shooting

1. If the controller goes offline, select [Communications] > [Settings], make sure the correct com port and baud rate is still selected, un-plug and plug-in the controller again, wait 10 seconds then select [Test Port] until Successful, then [Accept].

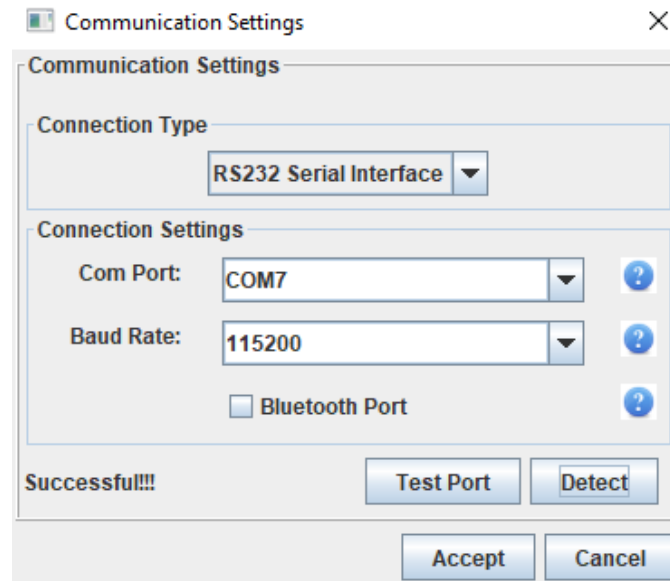

2. The computer may change the COM # after re-flashing a new map on the controller, try ignition cycle and re-plug the USB-C on the computer. Then jump back to step 7-10 above, under the software tuning section to find out which new COM port is used. Re-select the correct COM port, test port until successful, click [Accept] and it will connect to the controller again.

\*\*Some illustrations taken from the 2012-2013 Ford Focus Workshop Manual