



# INSTALLATION INSTRUCTIONS



2013 - 2015 Ford Focus ST 2.0L | PART NO. 15155

## BILL OF MATERIALS:

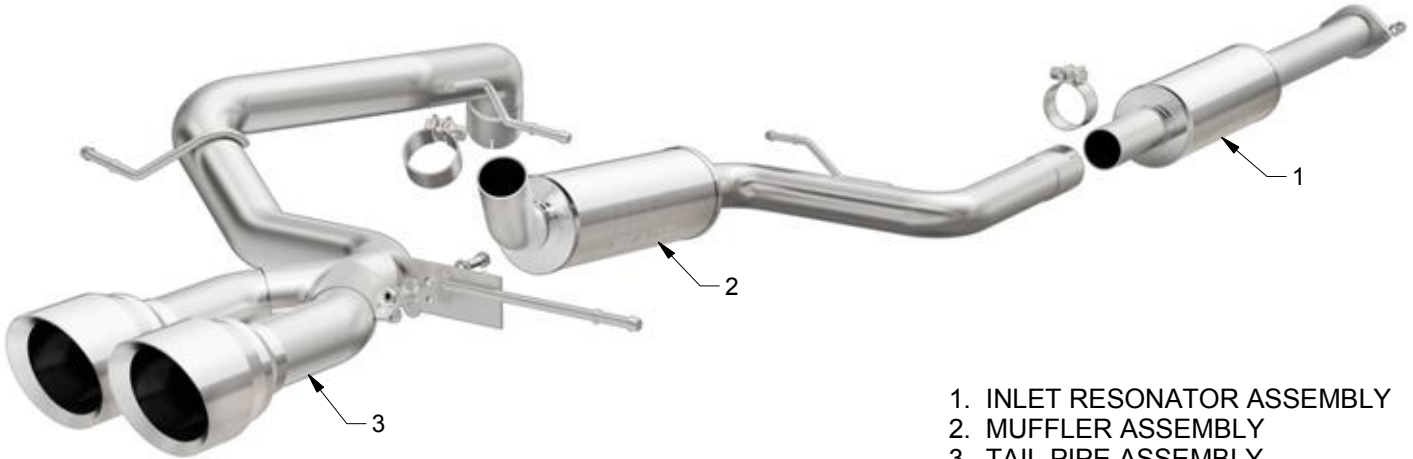

- 1. INLET RESONATOR ASSEMBLY
- 2. MUFFLER ASSEMBLY
- 3. TAIL PIPE ASSEMBLY



WEAR SAFETY GLASSES



READ INSTRUCTIONS THOROUGHLY BEFORE INSTALLING PRODUCT

## SHOP SUPPLIES:



SPRAY LUBRICANT

To ease removal of existing exhaust components (especially on older vehicles) spray penetrating lubricant on all fasteners and hangers/insulators that will be loosened or removed and let soak before disassembly.

## HARDWARE KIT:

- 1. [2] 2.50" BAND CLAMPS
- 2. [1] HANGER BRACKET
- 3. [2] 5/16" LOCK WASHER
- 4. [2] 5/16" FLAT WASHER
- 5. [2] 5/16" X 1.00" BOLT
- 6. [2] 5/16" NUTS
- 7. [2] 3/8" FLAT WASHER
- 8. [2] 3/8" X 1.00" BOLT
- 9. [2] 3/8" NUTS
- 10. [1] HANGER RUBBER



15mm Socket  
14mm Socket  
12mm Socket



Pry Bar

## MINIMUM REQUIRED TOOLS:

## MAGNAFLOW RECOMMENDS PROFESSIONAL INSTALLATION ON ALL THEIR PRODUCTS



**WARNING:** When working on, under, or around any vehicle exercise caution. Please allow the vehicle's exhaust system to cool before removal, as exhaust system temperatures may cause severe burns. If working without a lift always consult vehicle manual for correct lifting specifications. Always wear safety glasses and ensure a safe work area. Serious injury or death could occur if safety measures are not followed.

**ATTENTION:** Always install any supplied band or U-bolt clamps to the proper torque specifications of 40-45 ft-lbs for band clamps and 30-35 ft-lbs for U-bolt clamps. Over tightening will result in the clamp breaking and will NOT be warranted by MagnaFlow.



## INSTALLATION INSTRUCTIONS



**Step 1.** Remove the OEM system by first unbolting the two nuts at the flange attaching the stock inlet pipe to the catalytic converter.

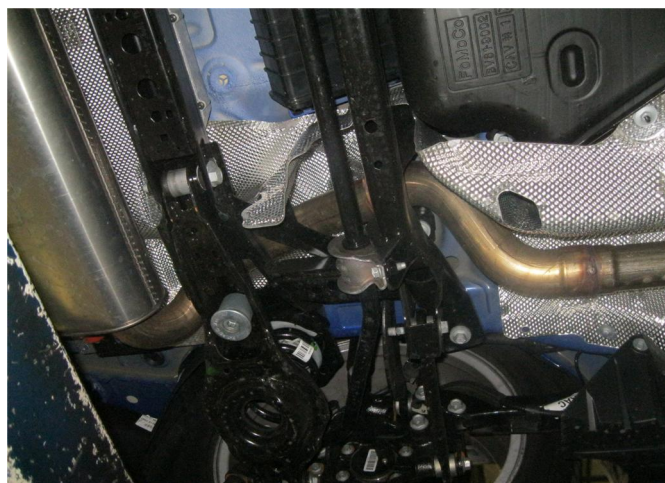

**Step 2.** To remove the OEM system you will need to cut the exhaust pipe at the over axle pipe. Disengage all welded hangers from the rubber isolators. The exhaust can now be removed. Retain all fasteners and insulators as they will be needed to mount your new MAGNAFLOW system.



**Step 3.** Install your new system by first attaching the Inlet Resonator Assembly to the catalytic converter outlet using the supplied hardware.

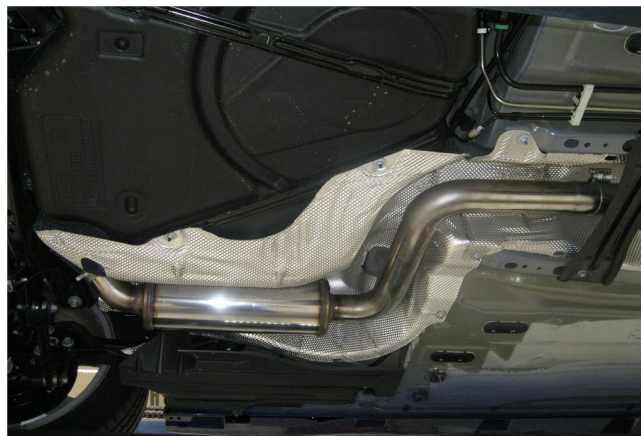

**Step 4.** Slip the inlet of the Muffler Assembly over the outlet of the Inlet Resonator Assembly and loosely secure using the supplied 2.50" band clamp. The supplied rubber insulated will be needed on 2015 applications only. Install the Tail Pipe Assembly in a similar fashion.



**Step 5.** With the complete system loosely mounted to the vehicle locate the supplied Hanger Bracket to the rubber insulator. Next, bolt the hanger Bracket to the Tip Y-Pipe Assembly using the supplied hardware.

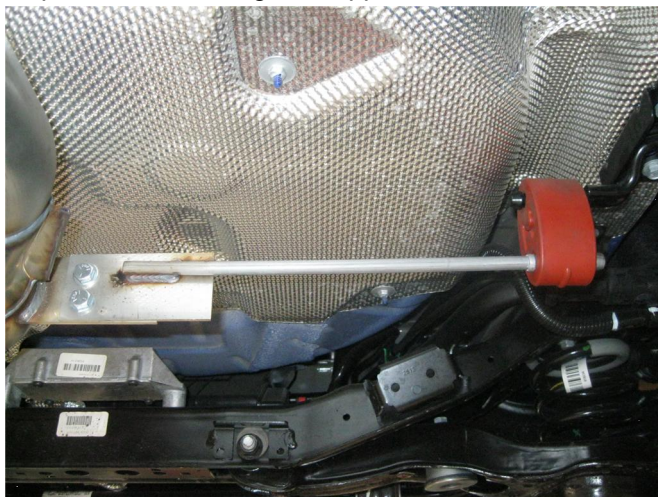



**Step 6.** Once a final position has been chosen for the new exhaust system, evenly tighten all clamps from front to rear using the torque specifications on page one of the instructions. Inspect all fasteners after 25-50 miles of operation and re-tighten if necessary.