

STRATIFIED AUX FUEL SYSTEM ECOBOOST 2.0/2.3

4-Port Fuel Injection System

Installation and User Guide





Thank you and congratulations on the purchase of your new Stratified 4-Port Auxiliary Fuel System. Follow this document to ensure safe and proper installation and operation of your new device.

WARNINGS AND WARRANTY – PLEASE READ CAREFULLY

ALL parts are sold for OFF ROAD RACE-ONLY ground vehicle use only. Aftermarket systems interacting with engine function are not for use on pollution controlled vehicles. Alteration of emission related components constitutes tampering under most local emission regulation guidelines and can lead to fines and penalties.

Limited Warranty

This Stratified product is warranted against defects in materials and workmanship for ninety (90) days from date of purchase. During the warranty period, Stratified will repair, or at its option replace at no charge, components that prove to be defective. The product must be returned, shipping prepaid, to a Stratified facility. This limited warranty does not apply if the product is damaged by accident or misuse. The foregoing warranty is in lieu of all other warranties expressed or implied including but not limited to any implied warranty of merchantability, fitness, or adequacy for any particular purpose or use. Stratified Automotive Controls Ltd. is not responsible for any fines, injuries, or damages incurred as a result of the installation or use or misuse of our products. It is the complete responsibility of the purchaser of such products to ensure that they are used in a legal, safe, and appropriate manner.

DISCONNECT THE NEGATIVE BATTERY TERMINAL BEFORE PERFORMING ANY ELECTRICAL WORK ON YOUR VEHICLE. IF YOU DO NOT FEEL COMFORTABLE MAKING THESE MODIFICATIONS, HAVE THEM PERFORMED BY A PROFESSIONAL.



Table of Contents

1.	Features and Benefits	4
2.	Introduction and Precautions.....	5
3.	Parts Included	6
4.	Installation Diagram.....	7
5.	Installation Instructions.....	8

1. Features and Benefits



Protects your Engine from Fuel Starvation:

To make more power you need two main components. Air and Fuel. With more boost and bigger turbochargers or superchargers, your OEM direct injection components can't supply the fuel needed for safe high power operation. This auxiliary port injection system is a proven method for keeping your motor safely fueled under the most demanding conditions.



Provides The Fuel you Need for More Boost and Power:

Direct injection cars use expensive and complex components. When upgrading your vehicle to produce more power than stock, more fuel is needed. Direct injection injectors and fuel pumps are often not upgradeable. This fuel system augments your fueling under high power levels with proven components allowing you to achieve your power goals.



Cleaner Valves, Efficient Motor:

The direct injection (DI) system is very efficient and has cooling benefits. Keeping it in the car and working as intended is ideal. This is why a port injection system works so well. You keep the efficient DI fueling and augment it with port injection only under high power. This also has the benefit of keeping your intake valves cleaner.



Easy Installation:

We have worked very hard to make our systems as plug and play as possible. The kit you purchased is built and tested for your vehicle. This means everything fits right and works as it should from the get-go making it a painless and effective installation process.



Tested, Proven, Safe Solution:

We don't build and sell anything that we don't thoroughly test. The fuel system is a proven, safe solution for increasing fueling on your vehicle and we stand behind its performance, capabilities, and reliability.



E85 Safe, Simple Adjustments:

All kit components are E85 safe. The controller that calculates the fuel delivery as well as all components are purpose built and safe. We make adjusting the fueling as simple as possible to make sure you get to your results quickly whether we tune the system or someone else does.



Split Port Directional Injection with Angled Port Matching:

Features injectors oriented towards the cylinder head that spray with a split stream pattern to ensure even fuel distribution to each intake valve. The ports on the spacer are also matched to the angle at the mating surface between the intake manifold and cylinder head to ensure that the transition of airflow towards the engine remains smooth.

2. Introduction and Precautions

IMPORTANT: When installing and working with the Auxiliary Fuel System you are working with flammable fluids. Take all safety precautions necessary during installation and operation of the fuel kit to prevent any fires or injuries. This means ensuring you are installing the system in a well-ventilated area away from any spark or flame source. After the installation and periodically thereafter check that the system continues to be leak free.

The Aux Fuel System Electronic Controller should be mounted within the vehicle's engine bay, but it is **NOT water proof**. The controller should not be mounted directly on the engine. Do not spray or pressure wash the controller with water or any other liquids. Mount the controller in an area that is not in contact with the engine - preferably close to other vehicle electronics such as the fuse box.

The direct injection (DI) system in your vehicle is designed to supply enough fuel to run the OEM vehicle with OEM components. Most manufacturers build some headroom into their fueling systems but at some point, your quest for power requires more fuel. On a direct injected car this means that you need to upgrade at least the fuel injectors or high pressure fuel pump or often both. These upgrades are expensive and often not available.

The Stratified 4-Port Auxiliary Fuel System is designed to work in conjunction with your DI fuel system and offer additional fuel when needed under high boost or high power demands. This means that your car remains efficient and driveable while having the fueling capacity to reach higher power goals.

3. Parts Included

Verify that all these components are included with your fuel system kit:

Item	Specifics
1x – X ⁴ tra Fuel Kit Assembly	<ul style="list-style-type: none"> • 1x – Intake Spacer • 1x – (-8 AN) ORB Plug • 3x – Fuel Rail Legs • 1x – Fuel Rail • 4x – Fuel Injector • 6x – M5 Bolts/Washers • 1x – Gasket Bracket • 6x – M6 Washers • 2x – M6 Bolts • 2x – Spacers
1x – Fuel Line Tap	N/A
1x – Fuel Line (2ft.) w/ Fittings	<ul style="list-style-type: none"> • 1x – (-8 AN) 90 Deg. Fitting • 1x – (-6 AN) 90 Deg. Fitting
Fuel System Controller Box	<ul style="list-style-type: none"> • 1x – 4-Port Controller w/ Strat Sticker • 1x – Add-a-fuse • 1x – 5A Fuse • 1x – Ring terminal • 1x – Tuning Required Sticker • 4x – Injector Connector
Hardware Bag	<ul style="list-style-type: none"> • 4x – FoMoCo Intake Gaskets • 5x – Posi-Taps • 5x – M8 40mm Bolts • 5x – M8 Washers • 15x – Zip Ties – Small • 2x – 3M Dual Lock Strips
5x – Zip Ties - 8" Large	N/A
1x – Fuel Disconnect Set	N/A
1x – Stratified Tuned Decal	N/A
1x – Business Card	N/A
1x – ½" Wire Loom (2.5 ft.)	N/A
OPTIONAL	<ul style="list-style-type: none"> • 1x – USB Tuning Cable



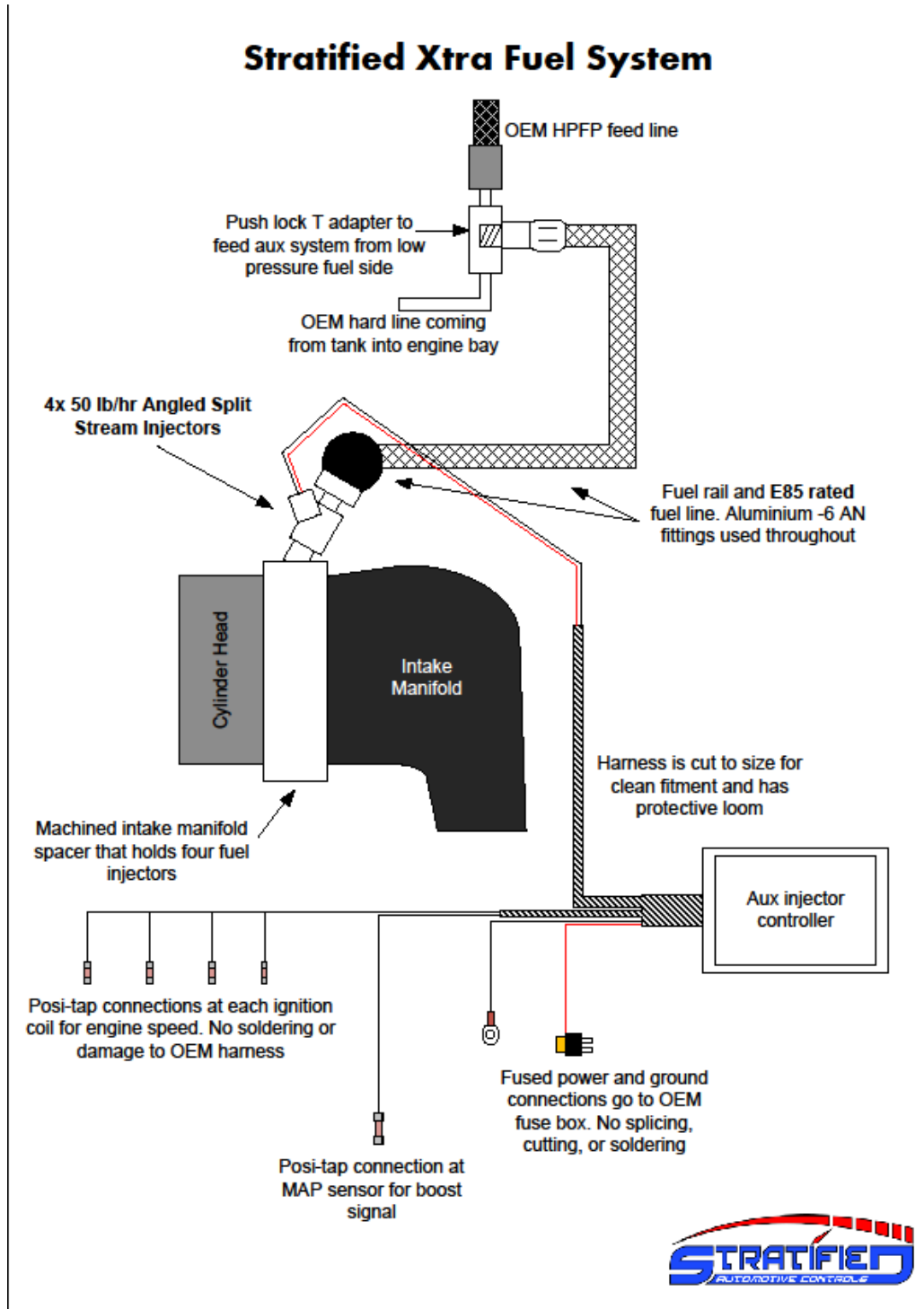

4. Installation Diagram



5. Installation Instructions

IMPORTANT: When installing and working with the Auxiliary Fuel System you are working with flammable fluids. Take all safety precautions necessary during installation and operation of the fuel kit to prevent any fires or injuries. This means ensuring you are installing the system in a well-ventilated area away from any spark or flame source. After the installation and periodically thereafter check that the system continues to be leak free.

 **WARNING:** Before working on or disconnecting any of the fuel tubes or fuel system components, relieve the fuel system pressure to prevent accidental spraying of fuel. Fuel in the fuel system remains under high pressure, even when the engine is not running. Failure to follow this instruction may result in serious personal injury.

 **WARNING:** Do not smoke, carry lighted tobacco or have an open flame of any type when working on or near any fuel-related component. Highly flammable mixtures are always present and may be ignited. Failure to follow these instructions may result in serious personal injury.

 **WARNING:** Clean all fuel residue from the engine compartment. If not removed, fuel residue may ignite when the engine is returned to operation. Failure to follow this instruction may result in serious personal injury.

 **WARNING:** Do not carry personal electronic devices such as cell phones, pagers or audio equipment of any type when working on or near any fuel-related component. Highly flammable mixtures are always present and may be ignited. Failure to follow these instructions may result in serious personal injury.

 **WARNING:** Always disconnect the battery ground cable at the battery when working on an evaporative emission (EVAP) system or fuel-related component. Highly flammable mixtures are always present and may be ignited. Failure to follow these instructions may result in serious personal injury.

 **WARNING:** When handling fuel, always observe fuel handling precautions and be prepared in the event of fuel spillage. Spilled fuel may be ignited by hot vehicle components or other ignition sources. Failure to follow these instructions may result in serious personal injury.

 **WARNING:** Avoid contact with fuel during a visual inspection for fuel leaks with the engine running. Do not work on the fuel system until the pressure has been released and the engine has cooled. Fuel in the high-pressure fuel system is hot and under very high pressure. High-pressure fuel may cause cuts and contact with hot fuel may cause burns. Failure to follow these instructions may result in serious personal injury

1. You must first relieve the fuel pressure in the OEM fuel system. This is done by pulling use F56 from the body control fuse module which is in the passenger footwell underneath the glove box.
2. Remove the panel insulator.

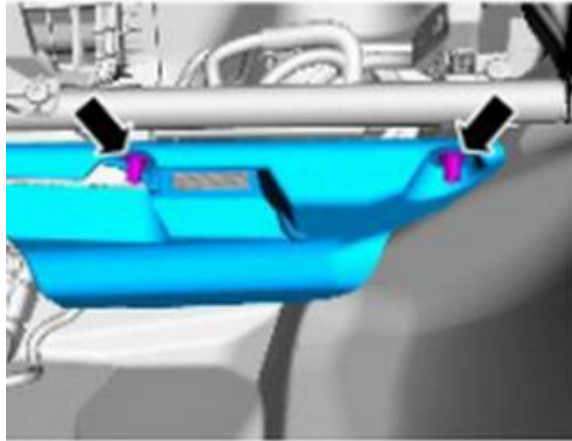

3. Remove Fuse F56 from the body control module.



4. Now start the car and wait for the engine to stall. Once it has stalled, crank for another 20 seconds to ensure fuel pressure is relieved.
5. Turn the key to the OFF position and keep the fuse out of the panel until the fuel kit installation is complete. This might trigger some engine codes. Clear these after the installation.
6. Remove the negative battery cable.

7. The intake spacer, rail and injectors should be installed next. The easiest way to install them is by removing the intake manifold from the vehicle and performing the installation on a bench. This also gives you the opportunity to inspect your intake valves. They will look cleaner after you run the aux fuel system!
8. Jack up the front of the vehicle and secure it.
9. Remove the underbody panels

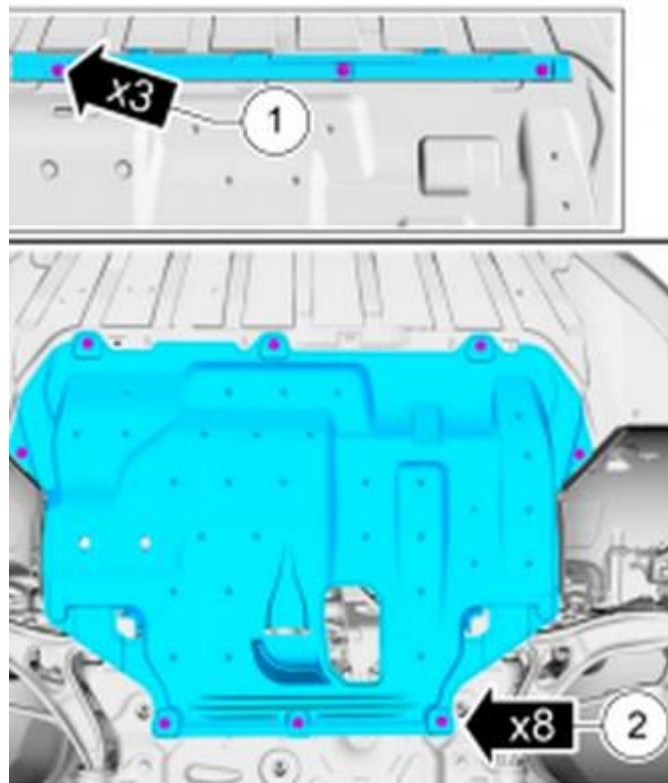

10. Disconnect your charge piping from the throttle body and push it down slightly.

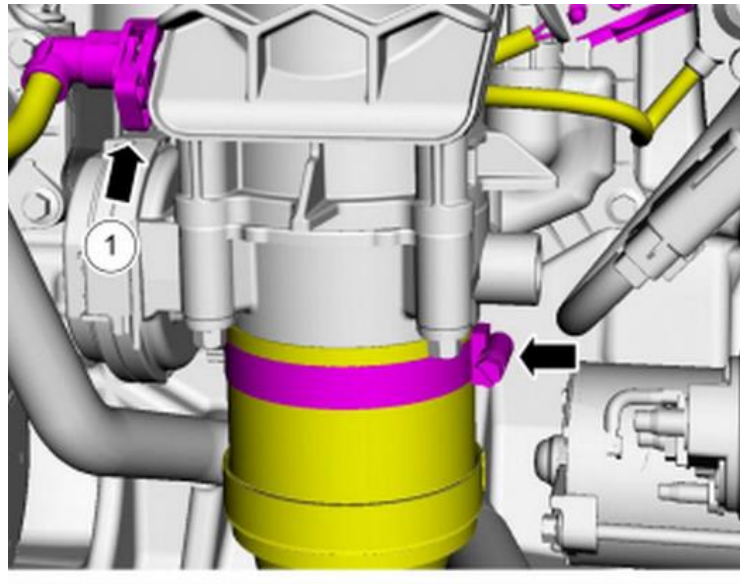

11. Disconnect the vacuum and electrical connections from the manifold and throttle body as shown below:

NOTE: The sound symposer may not fit with the fuel kit on the Focus ST. If you haven't already done so, remove the symposer and block it off with a plate.

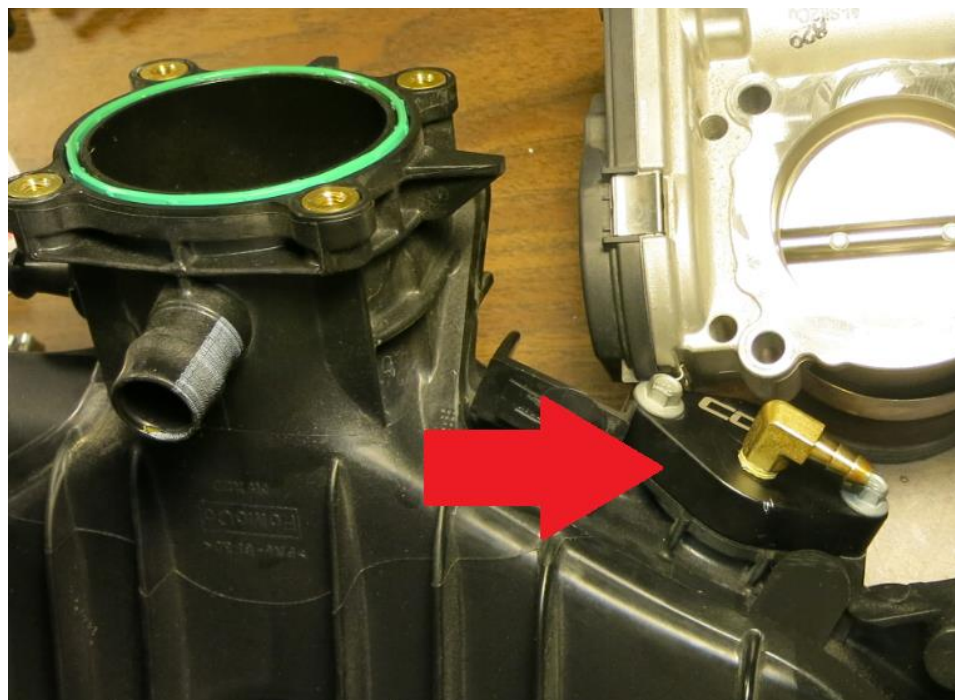

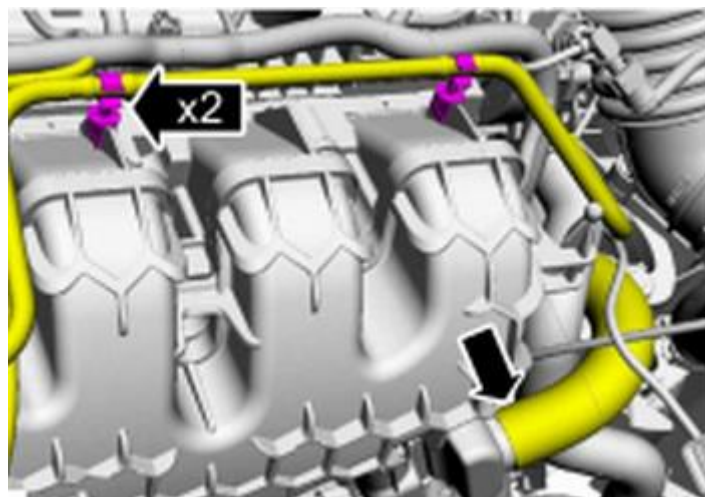
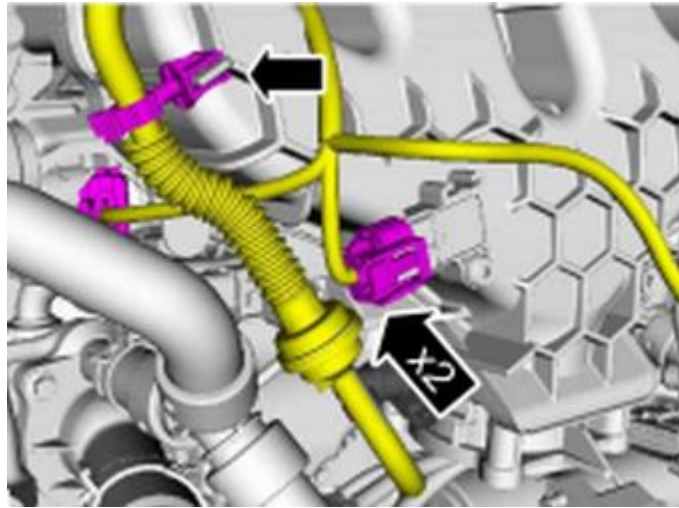

NOTE: The throttle body electrical connector can be a little tricky to disconnect. It might be useful to loosen the intake manifold to give yourself more clearance.

NOTE: Be careful with the quick connect vacuum hoses and lines. The clips can be fragile if not handled carefully.

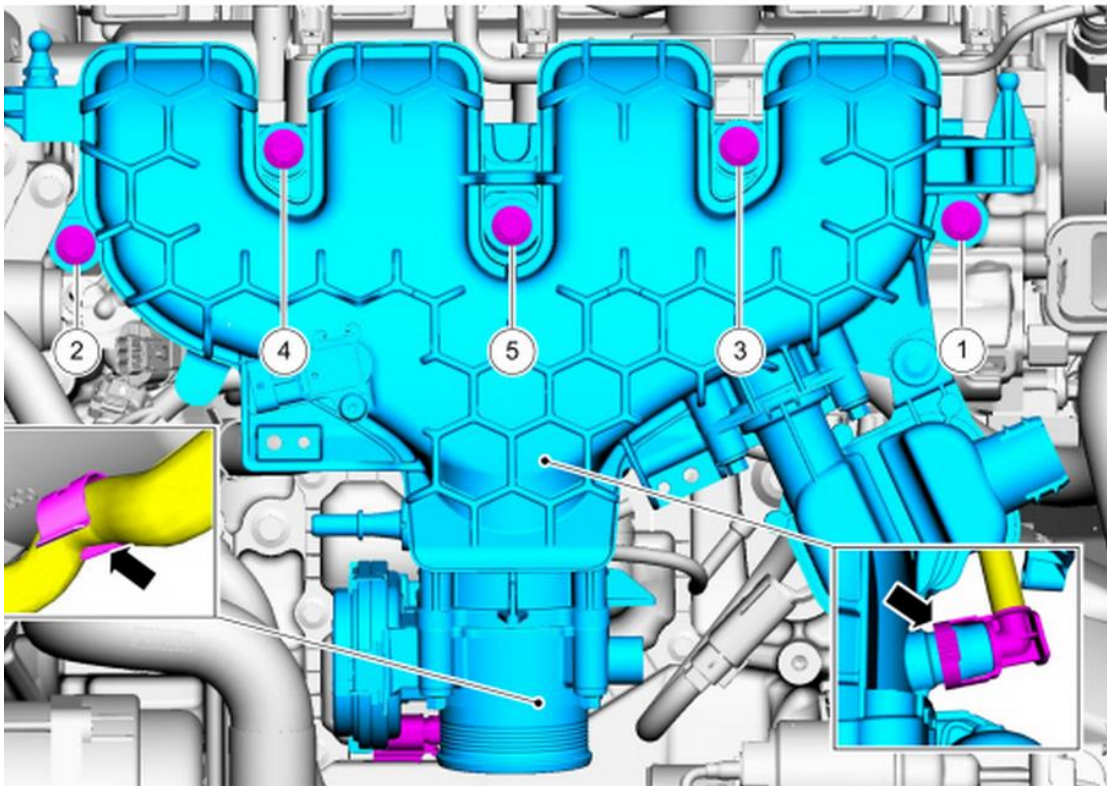
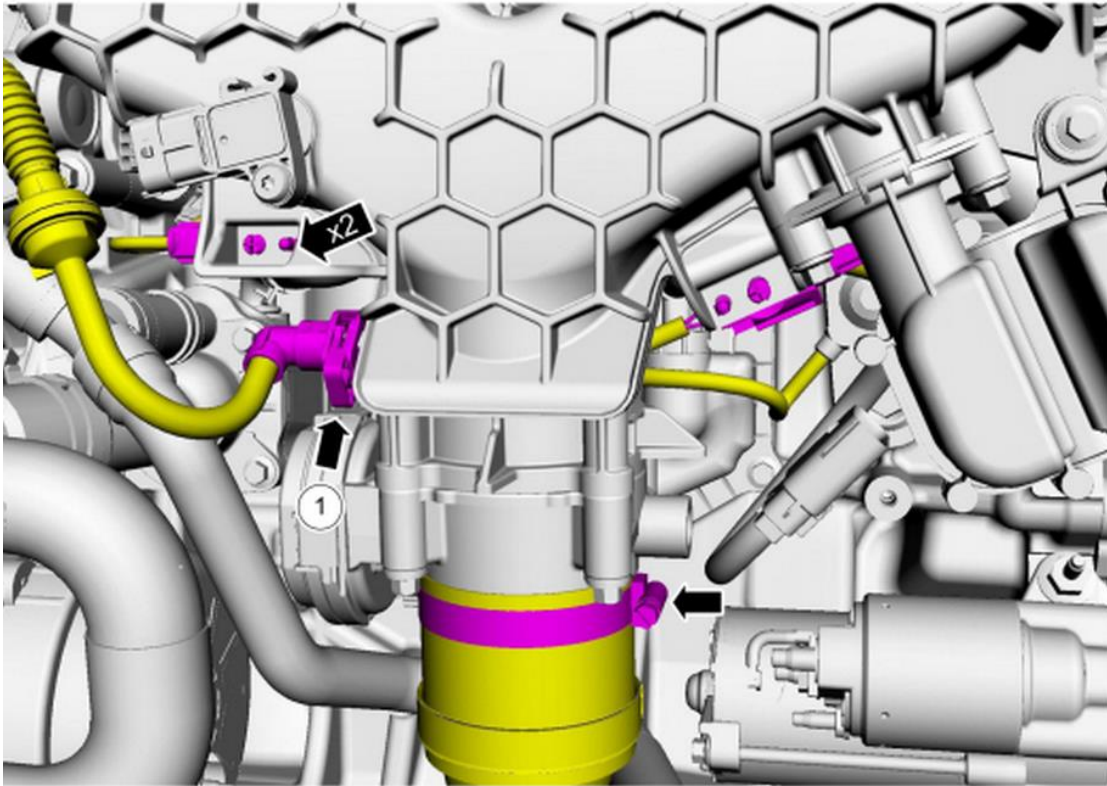

12. Inspect the manifold-to-head insulating gaskets.

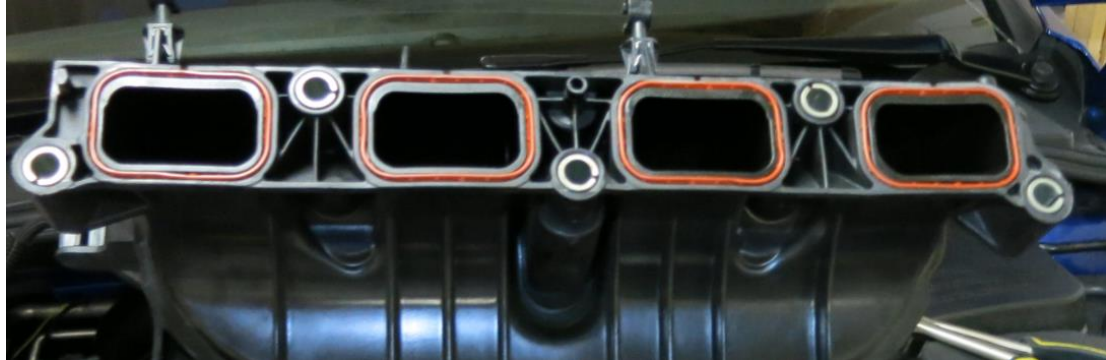

13. You will now have to modify the manifold to ensure proper fitment of the assembly.

14. Cut off the passenger ear right along the metal sleeve using a hack saw or something similar that will get the job done.

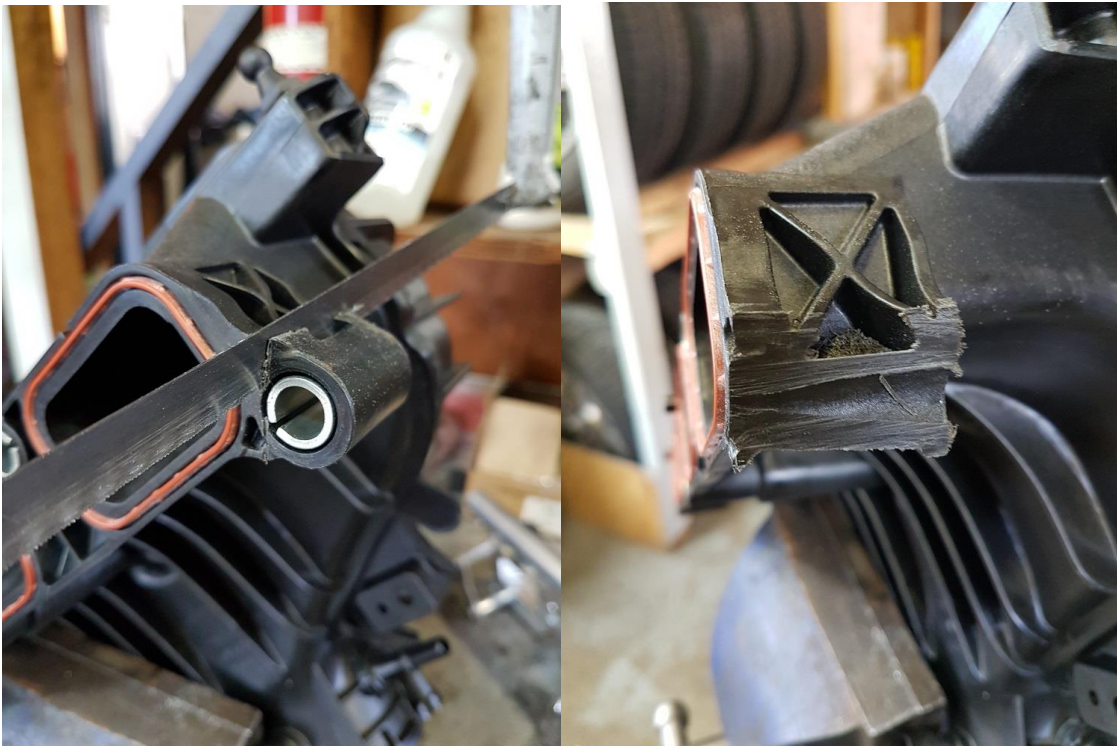

15. The backside of the ear will have a shelf that will allow that corner to be clamped down by a bracket as shown below.



16. Place the included FoMoCo gaskets into the grooves of the Intake Spacer



17. Mount the plate to the head using the M8 Washers and M8x40mm bolts provided.



18. Make sure the injector tab is lined up with the manifold tab where the gasket shows through. This will point the electrical connectors directly behind the rail.

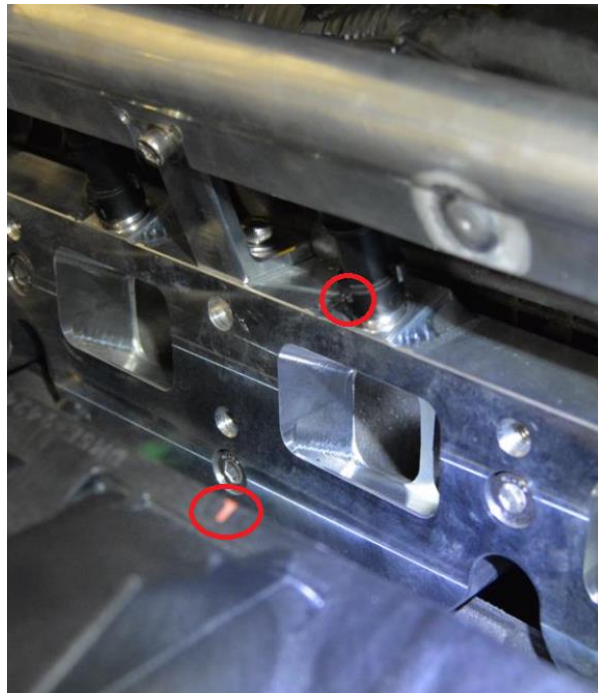

19. Slide the manifold modified ear behind the bracket and then clamp that corner down as shown in Step 15.
20. The installation of the intake spacer will offset the throttle body upwards and towards the front of the car. Massaging the couplers on the cold pipe will allow fitment.
21. You may need to slightly move the AC line towards the front of the car. Do this using your hand, it needs the slightest amount of bending to clear the manifold.
22. Install the manifold assembly back onto the engine and connect all hoses and electrical connections.
23. Install the Stratified Aux Fuel Flexible line -8AN male fitting onto the fuel rail. This connection does not need any sealants or tape.



24. Run the fuel line underneath the air intake tube and towards the rear of the motor watching that it does not come into contact with any abrasive surfaces.
25. Thread the Stratified Aux Fuel Flexible line -6AN male fitting into the provided fuel line tap. There is Teflon tape on the fitting, more or less may be needed if the line does not seal due to the nature of the tap.



26. Disconnect the high pressure fuel pump (HPFP) feed line from behind the HPFP. It is marked by a red arrow below. This rubber flexible feed line connects to a supply hard line coming from the tank. The line is 5/16" and the best tool to use for disconnecting it is the one supplied in the kit. Select the 5/16" collar from the kit.

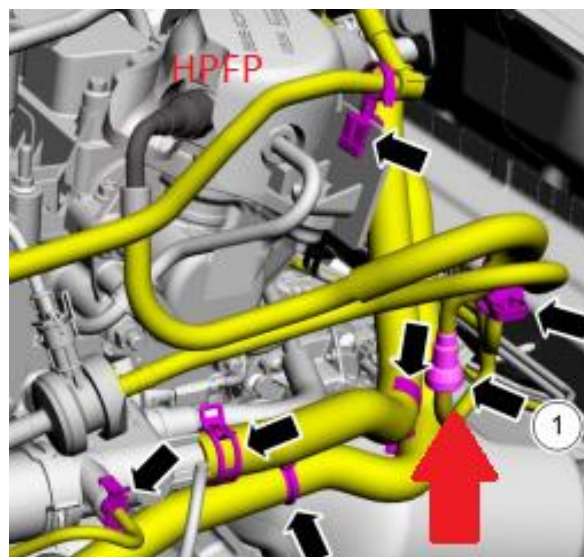

27. Place the 5/16" collar on the hard line where the arrow is pointing with the flat section away from the fuel line connector and push it between the connector and hard line. The connector should pop off without much force.

WARNING: Watch for fuel spray and leaking when disconnecting the fuel line.

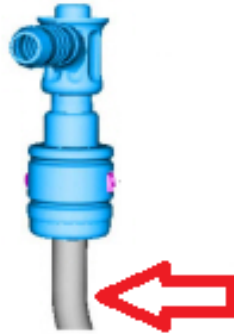

28. Place the fuel line tap on the 5/16" hard fuel supply line and re-attach the HPFP feed line to the top of the tap. Make sure all fuel connections click into place.

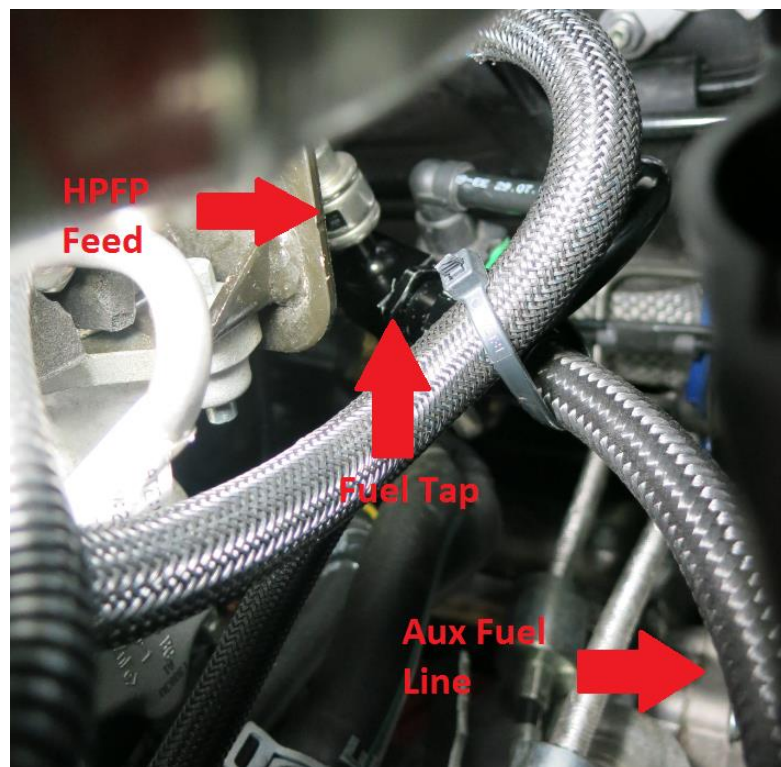

29. Secure the fuel line using the large Zip ties.
30. Now it is time to install the controller. Below is the controller and the wiring connections.

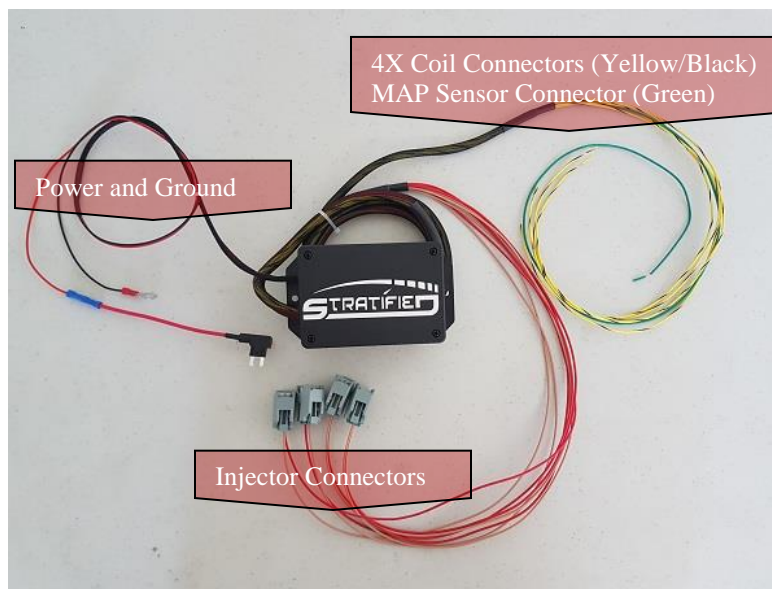

31. Start by removing the air filter box assembly from the engine bay.
32. Secure the Stratified Aux Fuel Controller to the top of the fuse box using the 3M dual lock provided.



33. Open the fuse box and install the Add-A-Fuse supplied to one of the switched fuse locations in the fuse box by the battery. We tested the location shown below. It **did not** have an existing fuse. If the location you use has an existing fuse, make sure that fuse is rated for at least 10A and is switched with ignition. Place the removed fuse in the second position of the Add-A-Fuse holder or that circuit will no longer work.

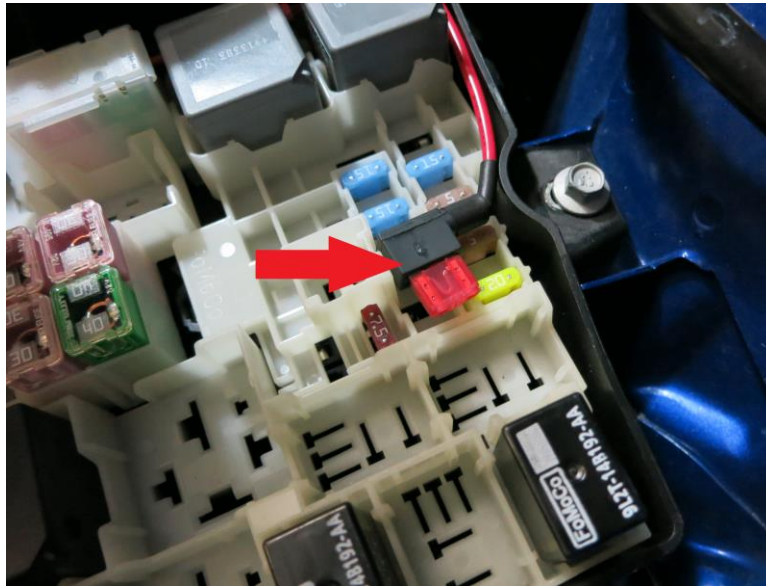

34. Locate the ground wire underneath the air filter box held by a 10mm bolt and bolt down the ring terminal from the Stratified Aux Fuel Controller harness.

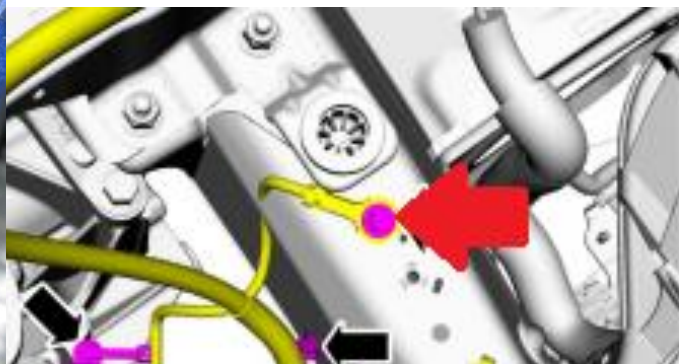

35. Run the four injector connectors and wires underneath the intake tube and connect them to the four auxiliary injectors.



36. Now it is time to get your tach signal connected. To do this you need to tap into the **leftmost** wire for **each** of the 4 coil packs. Each tapped coil pack connects to one of the 4 **yellow/black** wires of the Aux Fuel Controller.

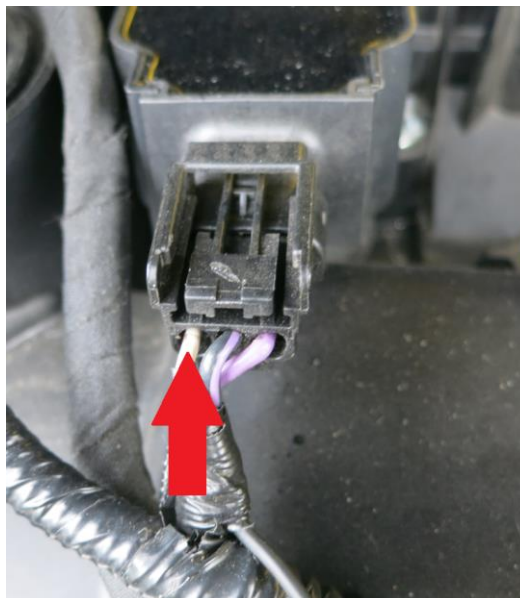

37. 4 Posi-Tap connectors are provided for this task. Installing these is simple as shown below and does not damage the wires. The order in which you connect each coil pack to the yellow/black wires does not matter. Ensure that the wires are routed well and securely connected.

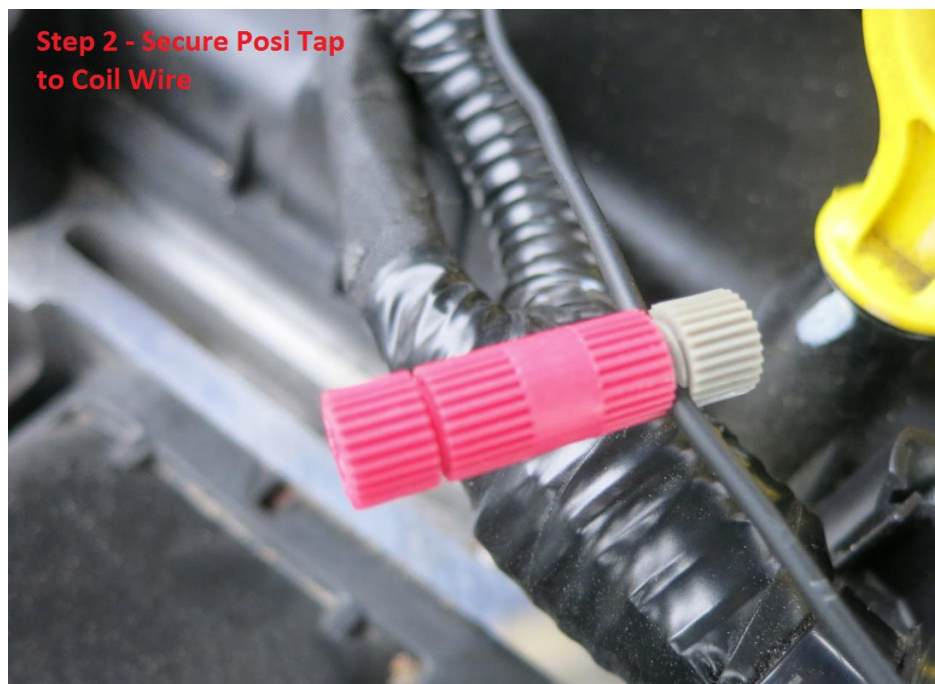
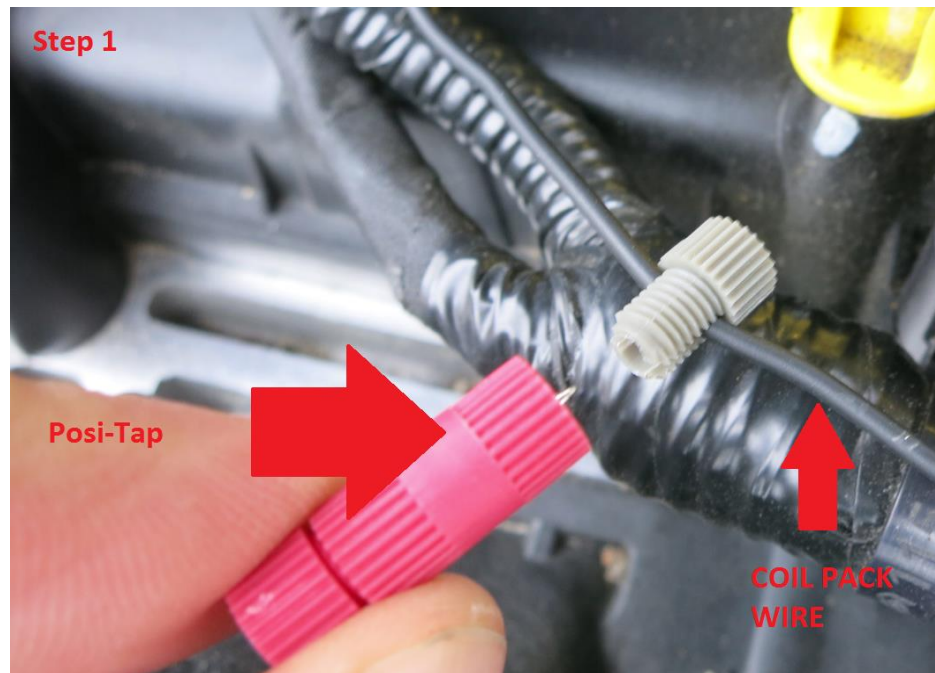

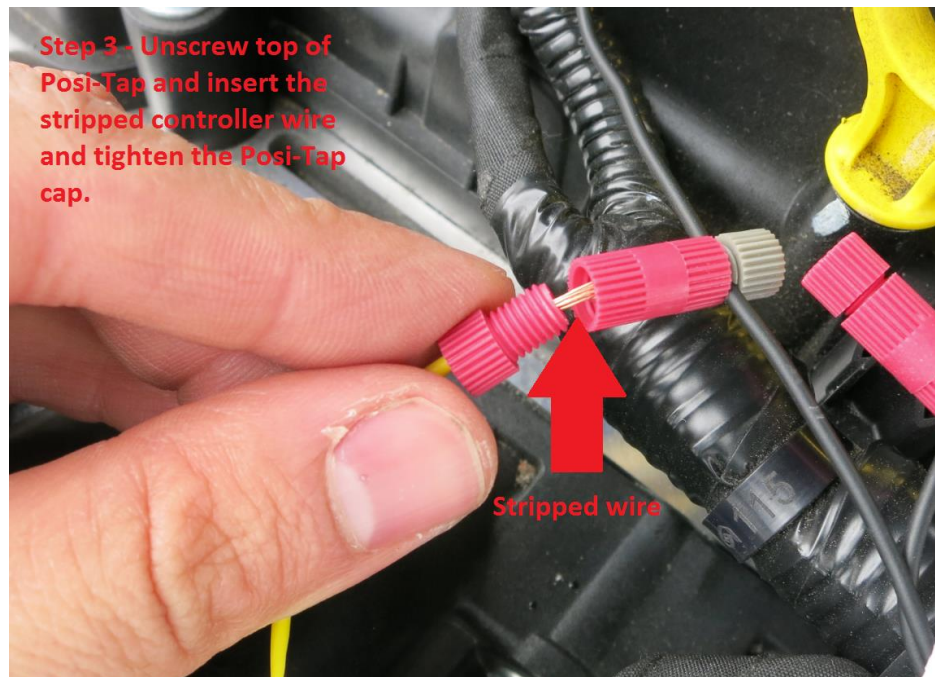

38. Now it's time to connect to the MAP sensor wire. The OEM MAP sensor wire is the leftmost on the connector. Most cars have this as gray or gray/purple. Use a Posi-Tap connector to connect this MAP sensor wire to the **green** wire on the Aux Fuel Controller.

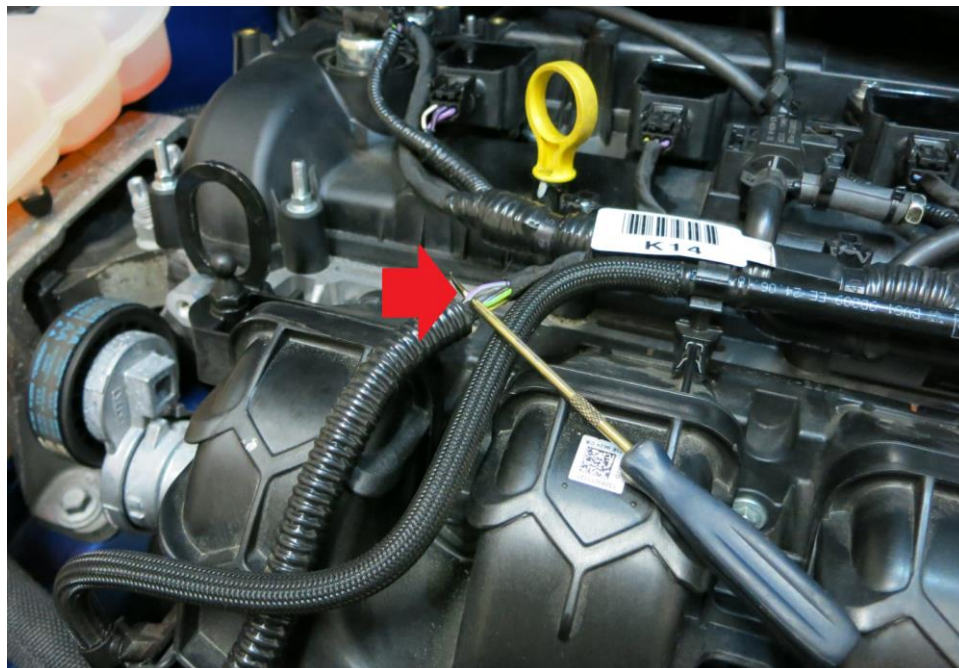

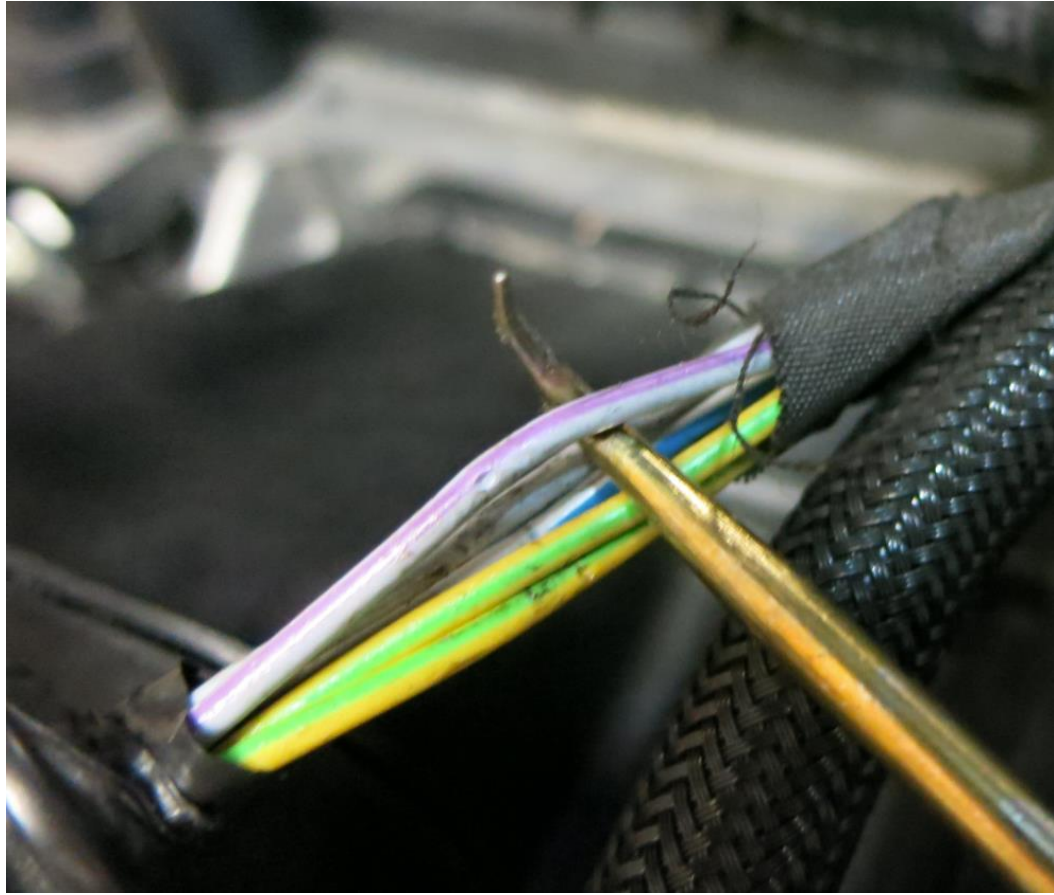

39. Use the included loom to bundle the wiring behind the rail and strapping it down.
40. Using the small Zip Ties, bundle and secure the wiring loom so that it is not going to rub or become damaged over time.



41. Now that everything is in place, reinstall the air filter box and check all your electrical, vacuum, and fuel connections.
42. Get your tuning laptop ready and make sure it has the Split Second R4 tuning software installed that was supplied with the Aux Fuel Controller.
43. Replace fuse F56 in the passenger footwell body control module.
44. Reconnect the battery.
45. Turn the key to the ON position to prime the fuel system but do not start the car. Go to the engine bay and ensure there are no fuel leaks of any kind.
46. Remove the 4 Phillips screws that hold the lid on the Stratified Aux Fuel Controller.

47. Using a serial cable or Serial-USB converter connect the controller to your laptop computer.



48. Open the R4 software on your computer. Click on File → New Customer and create a new profile.
49. Open the customer you have just created: File → Open Customer.

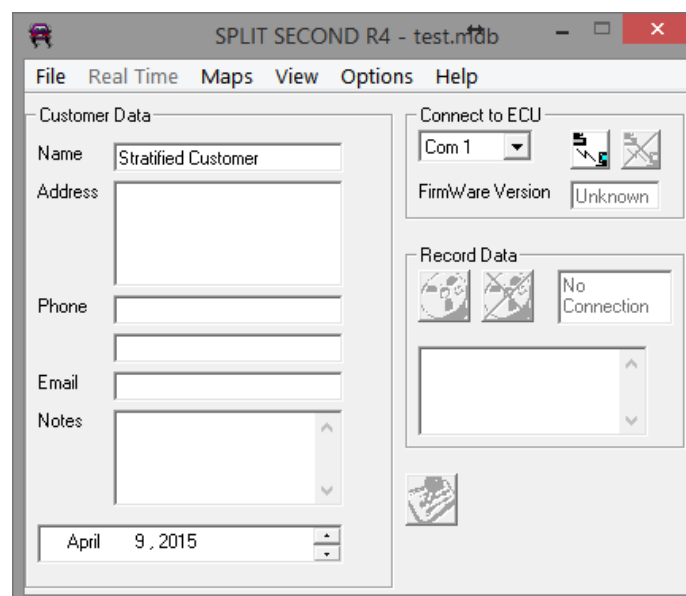

50. Go to Options → System Settings and ensure everything is set as shown below:

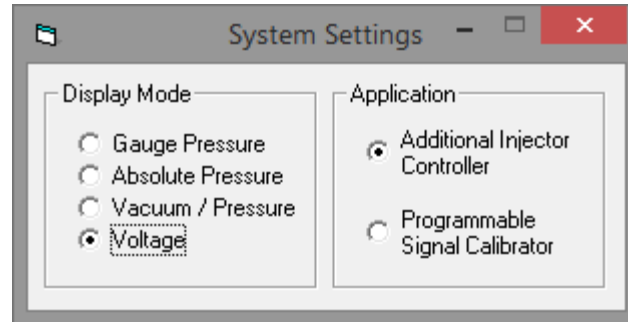

51. Go to Options → Engine Settings and ensure everything is set as shown below:

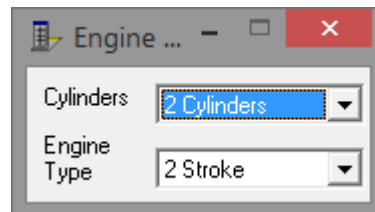

52. Now that your controller is setup, you have to set how much and when to inject the additional fuel. This is contained in the Maps → Fuel Maps. Here you are able to enter in milliseconds the injector opening time and this is where you tune the additional fuel.

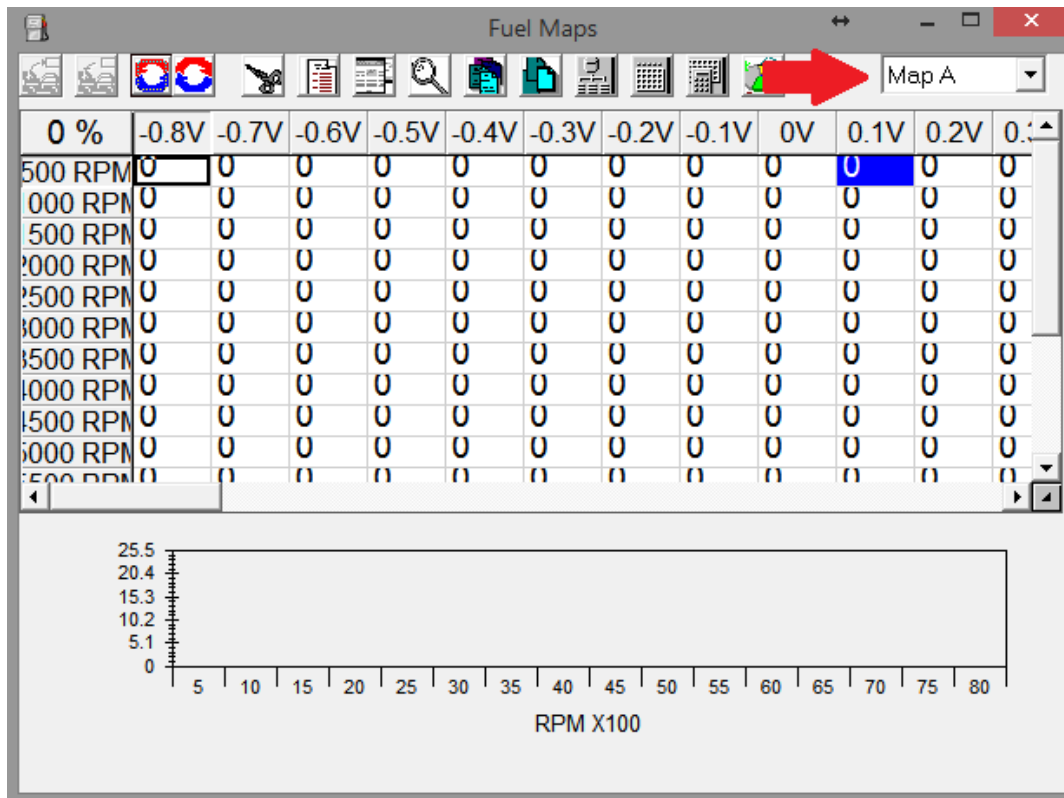

53. The fuel controller comes with its own set of instructions if you would like to tune the system. If you would like the system tuned for you, we are more than happy to assist with your Stratified Aux Fuel System tuning for an additional fee.
54. Before tuning it's a good idea to test that the system is reading engine speed and the MAP sensor correctly. To do so, make sure that fueling Map A and Map B (selectable from the Fuel Maps window drop down) have 0s for all the map values.
55. After entering 0s, close the Fuel Maps window and select the correct COM port in the R4 software to connect to your USB-Serial converter and computer. Then click the Connect to ECU button. Make sure the ignition key is ON and the car is not started

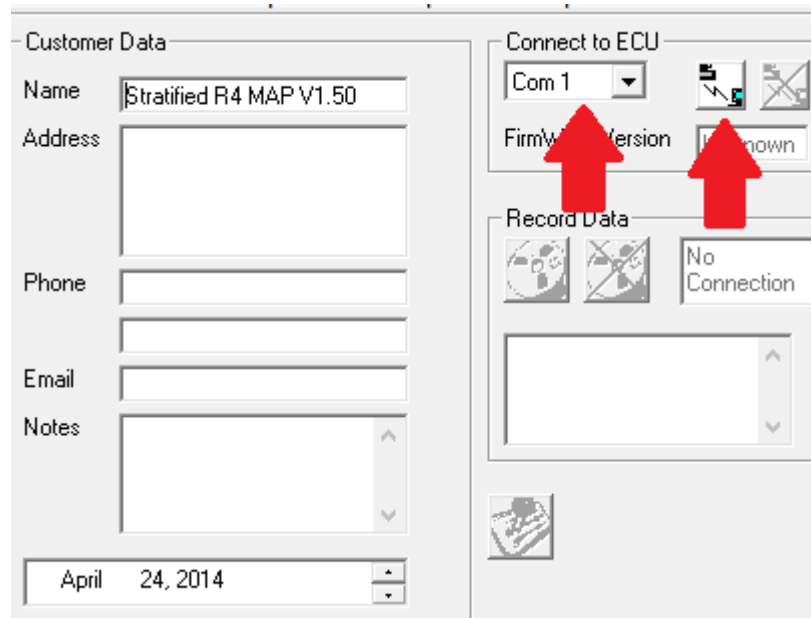

56. If the controller is powered and the computer is communicating with it, you will see the Record Data button become active (not grayed out)
57. At this point you can Flash a tune to the Aux Fuel System Controller. To do this you must go the Fuel Maps and click the Flash to Controller button (which is not grayed out when you are connected to the controller and it is powered).

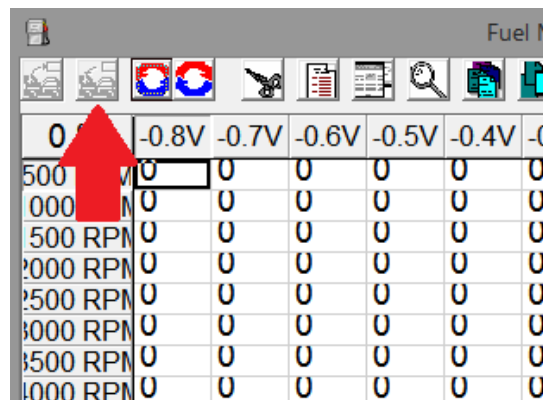

	0	-0.8V	-0.7V	-0.6V	-0.5V	-0.4V	0
500 RPM	0	0	0	0	0	0	0
1000 RPM	0	0	0	0	0	0	0
1500 RPM	0	0	0	0	0	0	0
2000 RPM	0	0	0	0	0	0	0
2500 RPM	0	0	0	0	0	0	0
3000 RPM	0	0	0	0	0	0	0
3500 RPM	0	0	0	0	0	0	0
4000 RPM	0	0	0	0	0	0	0

58. You will see a progress bar and once it has completed the Aux Fuel System Controller has been flashed.

59. To check the operation of the Controller, go to **Real Time** and open up the **All** option. **With the Key ON and engine OFF you should see the Volts box show approximately 1.6V with the OEM 3 bar MAP sensor. RPM will read 0.**
60. Turn the engine on and hold your foot on the throttle to hold the engine speed above 2000 RPM and below 3000 RPM. **You should see the RPM match your tachometer in your dash. The Voltage should read below 1.0V.**

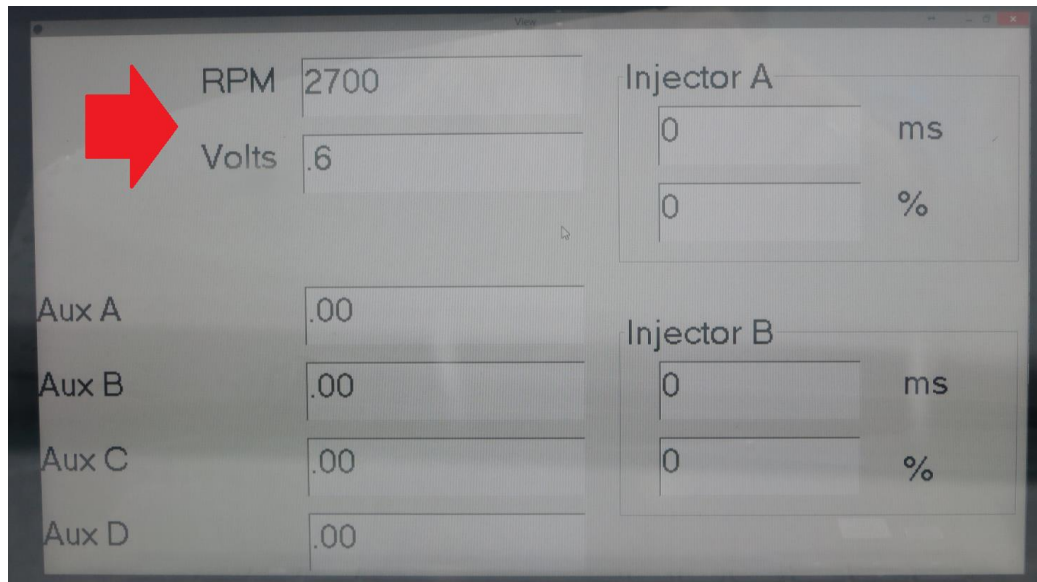

NOTE: Below 1500 RPM you will see that the RPM on the Aux Fuel Controller will not match the actual engine speed. **This is normal** and only happens at very low engine speeds (below 1500 RPM) where additional fueling is not needed.

61. Congratulations, your fuel system is now setup. Time to tune it and enjoy the added fueling and performance!

**Some illustrations taken from the 2012-2013 Ford Focus Workshop Manual